



By Irontite Products Inc.

Flywheel Grinders

Models FG5000 / FG10000



Instruction Manual and Parts List



MANUFACTURER OF IRONTITE, VAN NORMAN, AND KWIK-WAY BRAND PRODUCTS
Irontite Products Inc. PO Box 9877, Cedar Rapids, IA 52409 USA 800-553-5953 319-377-9101 (FAX)

Copyright © 2018 by Irontite Products Inc. All Rights Reserved. Rev. 181102

Equipment specifications, options and accessories subject to change without notice.



Warranty for Flywheel Grinders

Irontite Products Inc. ("IRONTITE") warrants to the original purchaser (the "Purchaser"), other than a purchaser for resale (the "Distributor"), that IRONTITE's machine tools shall be free of defects in materials and workmanship, for a period of one (1) year from completion of installation, or for a period of fifteen (15) months from date of shipment, whichever is earlier. IRONTITE will, at its sole and exclusive discretion, either replace or repair any machine or part thereof defective in workmanship or material, at no charge to the Purchaser.

All warranty repairs must either be performed by or authorized by an IRONTITE Authorized Service Organization. To obtain warranty service, Purchaser must contact IRONTITE. Purchaser must provide verification of date of delivery or installation (dated installation report) when requesting warranty service. Ground freight charges (UPS regular or common carrier truck) for all warranty replacement parts are paid by IRONTITE. Materials or parts alleged to be defective shall be returned to IRONTITE at IRONTITE's request, transportation charges prepaid. After the warranty repair or replacement of a defective part, IRONTITE's warranty for such part shall continue for ninety (90) days or for the remainder of the original Limited Warranty, whichever is longer.

WARRANTY LIMITATIONS

This warranty shall remain in effect only if the machine is used and maintained in accordance with all operating and maintenance instructions set forth in the manuals and instruction sheets furnished by IRONTITE. IRONTITE shall have no liability to repair or replace defective parts until the Purchaser has fulfilled its payment obligations. No allowance will be made for repairs or alterations made without IRONTITE's prior written consent or approval. The Limited Warranty provided by IRONTITE excludes the following:

1. Damage, malfunction, or failure caused by or resulting from improper maintenance, misuse, neglect, accident or any other cause beyond the control of IRONTITE.
2. Damage, malfunction, or failure caused by or resulting from modification of the machine (mechanical or electrical) without written authorization by IRONTITE.
3. Damage, malfunction, or failure caused by or resulting from installation or use of accessories or peripherals not purchased through or authorized in writing by IRONTITE.
4. Paint, batteries, filters, fluids, fuses, light bulbs, or any commonly expendable items.
5. Damage to machines and/or components while being transported from IRONTITE's warehouse or facility to destination.
6. Accessories or peripherals not manufactured by IRONTITE, which shall be subject to only whatever warranty that is supplied by the manufacturer of such product.
7. Controls, spindle and servo motors, spindle and servo drives, gear motors and gearboxes which shall be subject to only whatever warranty that is supplied by the manufacturer of such product.

No person, agent, distributor, dealer or company is authorized to change, modify or amend the terms of this Limited Warranty in any manner. IRONTITE makes no warranties, guarantees or representations, express or implied with respect to the machine tool, or parts thereof, except to the extent such warranty is set forth herein. The equipment covered does not necessarily comply with any codes or standards unless specifically quoted, ordered, and so accepted.

THIS WARRANTY IS IN LIEU OF ALL OTHER WARRANTIES, EXPRESS OR IMPLIED, INCLUDING WITHOUT LIMITATION WARRANTIES OF MERCHANTABILITY OR FITNESS FOR ANY PARTICULAR USE OR PURPOSE. IRONTITE's LIABILITY UNDER THIS WARRANTY IS EXPRESSLY LIMITED TO ITS PROMISE TO REPAIR OR REPLACE THE DEFECTIVE GOODS. IRONTITE SHALL HAVE NO FURTHER LIABILITY IN CONTRACT OR NEGLIGENCE OR UNDER ANY OTHER THEORY OF LAW OR EQUITY FOR ANY DAMAGES, DIRECT OR INDIRECT, INCIDENTAL, SPECIAL OR CONSEQUENTIAL, OR ANY DELAY RESULTING FROM THE DEFECT.

Because of Irontite Products Inc.'s constant program of product improvement, specifications are subject to change without notice.

For further information or questions, please contact
Irontite Products Inc. at: **800-553-5953** or fax **319-377-9101**.

KEEP THIS WARRANTY FOR YOUR RECORDS

Model #: _____ Serial #: _____ Purchase Date: _____

RECEIVING SHIPMENT

Upon taking delivery of your machine, carefully inspect the assembly before removing the crating and packing materials.

If evidence of damage exists, contact the shipper and Van Norman immediately. Although Van Norman is not responsible for damage incurred during transit, you will be provided assistance in preparation and filing of any necessary claims.

CAREFULLY READ THIS MANUAL BEFORE ATTEMPTING TO SETUP OR OPERATE THIS MACHINE.

IMPORTANT NOTE

Always have your serial number ready when communicating with Van Norman regarding parts or service.

Keep this manual in a safe place.

Date Received: _____

Serial Number: _____
(Serial Number location: Upper left corner at rear of unit)



Van Norman
Manufactured by Irontite Products Inc.
PO Box 9877, Cedar Rapids, IA 52409
800-553-5953 319-377-9421
(FAX) 319-377-9101

SAFETY FIRST

This manual has been prepared for the owner and those responsible for the maintenance of this machine. Its purpose aside from proper maintenance and operations, is to promote safety through the use of accepted practice. READ THE SAFETY AND OPERATING INSTRUCTIONS THOROUGHLY BEFORE OPERATING THE MACHINE.

In order to obtain maximum life and efficiency from your machine, follow all the instructions in the operating manuals carefully.

The specifications put forth in this manual were in effect at the time of publication. However, owing to Van Norman's policy of continuous improvement, changes to these specifications may be made at any time without obligation.



SAFETY INSTRUCTIONS

1. Read, understand and follow the safety and operating instructions found in this manual. Know the limitations and hazards associated with operating the machine.
2. Eye Safety: Wear an approved safety face shield, goggles or safety glasses to protect eyes when operating the machine.
3. Grounding the Machine: Machines equipped with three prong grounding plugs are so equipped for your protection against shock hazards and should be plugged directly into a properly grounded three-prong receptacle in accordance with national electrical codes and local codes and ordinances. A grounding adapter may be used. If one is used, the green lead should be securely connected to a suitable electrical ground such as a ground wire system. Do not cut off the grounding prong or use an adapter with the grounding prong removed.
4. Work Area: Keep the floor around the machine clean and free of tools, tooling, stock scrap and other foreign material and oil, grease or coolant to minimize the danger of tripping or slipping. Van Norman recommends the use of anti-skid floor strips on the floor area where the operator normally stands and that each machine's work area be marked off. Make certain the work area is well lighted and ventilated. Provide for adequate workspace around the machine.
5. Guards: Keep all machine guards in place at all times when machine is in use.
6. Do Not Overreach: Maintain a balanced stance and keep your body under control at all times.
7. Hand Safety: NEVER wear gloves while operating this machine.
8. Machine Capacity: Do not attempt to use the machine beyond its stated capacity or operations. This type of use will reduce the productive life of the machine and could cause the breakage of parts, which could result in personal injury.
9. Avoid Accidental Starting: Make certain the main switch is in the OFF position before connecting power to the machine.
10. Careless Acts: Give the work you are doing your undivided attention. Looking around, carrying on a conversation and horseplay are careless acts that can result in serious injury.
11. Job Completion: If the operation is complete, the machine should be emptied and the work area cleaned.
12. Disconnect All Power and Air to Machine before performing any service or maintenance.
13. Replacement Parts: Use only Van Norman replacement parts and accessories; otherwise, warranty will be null and void.
14. Misuse: Do not use the machine for other than its intended use. If used for other purposes, Irontite Products Inc./Van Norman disclaims any real or implied warranty and holds itself harmless for any injury or loss that may result from such use.

ELECTRICAL REQUIREMENTS — FG5000

**ELECTRICAL REQUIREMENTS
FG10,000 STANDARD**

PART NUMBER	DESCRIPTION/ ELECTRICALS	AMP SERVICE REQD.	MIN. WIRE SIZE
FG5000			
794-8690-00	208-230V, 60 Hz, 3 Ph	30	12
794-8690-01	208-230V, 60 Hz, 1 Ph	60	8
794-8690-02	460V, 60 Hz, 3 Ph	20	14
FG5000 WITH POWERHEAD			
794-8688-40	208-230V, 60 Hz, 3 Ph	30	12
794-8688-41	208-230V, 60 Hz, 1 Ph	60	8
794-8688-43	460V, 60 Hz, 3 Ph	20	14
FG5000 WITH POWERHEAD AND AUTOGRIND™			
794-8688-50	208-230V, 60 Hz, 3 Ph	30	12
794-8688-51	208-230V, 60 Hz, 1 Ph	60	8
794-8688-53	460V, 60 Hz, 3 Ph	20	14

PART NUMBER	DESCRIPTION/ ELECTRICALS	AMP SERVICE REQD.	MIN. WIRE SIZE
FG10,000 WITH POWERHEAD			
794-8688-22	208-230V, 60 Hz, 3 Ph	60	8
794-8688-36	460V, 60 Hz, 3 Ph	30	12
FG10,000 WITH POWERHEAD AND AUTOGRIND™			
794-8688-06	208-230V, 60 Hz, 3 Ph	60	8
794-8688-38	460V, 60 Hz, 3 Ph	30	12

* 380V, 50 Hz, 3 Ph – Available for special orders
 * 415V – Available for special orders

SPECIFICATIONS - FG5000 / FG10,000

	FG5000	FG10,000
Work Piece Capacity	24" (600 mm)	24" (600 mm)
Table Diameter	18" (450 mm)	18" (450 mm)
T-Slots in Table	6	6
Table Support Diameter	15" (381 mm)	15" (381 mm)
Column Diameter	4.44" (111.8 mm)	5.5" (139.7 mm)
Vertical Head Travel	8.75" (222.3 mm)	10.5" (266.7 mm)
Max. Height Table/Wheel	8.75" (222.3 mm)	10.5" (266.7 mm)
Grinding Motor @ 3500 RPM	5 Hp (3.5 Kw)	10 Hp (7 Kw)
Table Motor @ 16 RPM	1/3 Hp (0.233 Kw)	1/3 Hp (0.233 Kw)
Coolant Capacity, Standard	9.5 Gal (36 Liters)	9.5 Gal (36 Liters)
Height (overall)	69" (1752 mm)	69" (1752 mm)
Height (to table)	34.6" (878 mm)	34.6" (878 mm)
Width	34.5" (876 mm)	34.5" (876 mm)
Depth	36" (914.4 mm)	36" (914.4 mm)
Net Weight	1350 Lbs (612.4 kg)	1550 Lbs. (703.1 kg)
Ship Weight	1500 Lbs. (680.4 kg)	1700 Lbs. (771.1 kg)

STANDARD EQUIPMENT — FG5000/ FG10000

(Image on next page)

ITEM	PART #	DESCRIPTION	QTY
1	794-8010-64	Centering Cone Bolt 1.88" (47.6 mm)	1
2	794-8010-65	Centering Cone Bolt 2.375" (60.3 mm)	1
3	794-8010-66	Centering Cone Bolt 3.375" (87.8 mm)	1
4	794-8010-72	Centering Cone 1"-1.75" (25.4-44.5 mm)	1
5	794-8010-74	Centering Cone 1.312"-2" (33.3-50.8 mm)	1
6	794-8010-76	Centering Cone 1.75"-2.5" (44.5-63.5 mm)	1
7	794-8017-93	Centering Cone 2"-2.625" (50.8-66.7 mm)	1
8	794-8010-78	Centering Cone 2.25"-3" (57.2-76.2 mm)	1
9	794-8010-80	Centering Cone 2.75"-3.5" (69.9-88.9 mm)	1
10	794-8010-90	Flange Adaptor 3" (76.2 mm)	1
11	794-8010-92	Flange Adaptor 4" (101.6 mm)	1
12	794-8010-94	Flange Adaptor 5" (127 mm)	1
13	794-8010-97	Flange Adaptor 5.875" (149.2 mm)	1
14	794-8124-71	Wheel Spacer 1.5" (38.1mm)	1
15	794-8011-28	Grinding Wheel 4" (101.6 mm) Flaring Cup (FG5000)	1
16	794-8011-12	Grinding Wheel 6" (152.4 mm) Flaring Cup (FG5000)	1
17	794-8011-30	Grinding Wheel 6" (152.4 mm) Flaring Cup (FG5000)	1
18	794-8011-88	Lower Wheel Flange	1
19	794-8017-44	E-Z Lock Inserts	2
20	794-8011-52	Leadscrew Lubricant	1
21	794-8011-40	Coolant Additive, 1 qt. (.946 liter)	1
22	794-8011-55	Table Lubricant, 1 qt. (.946 liter)	2
23	000-0110-37	Leveling Bolts (Hex Head Cap Screws)	4
24	000-1035-35	Leveling Bolt Lock Nuts	4
25	794-8030-58	Leveling Pads	4
26	794-8637-45	E-Z Lock Insert Extractor	1
27	794-8013-73	Table Oil Level Gauge	1
28	794-8017-32	T-Handle Hex Wrench	1
29	794-8017-37	Wrench Set (Includes):	1
	000-0600-18	3/8" Hex Wrench	1
	000-0600-20	5/16" Hex Wrench	1
	000-0600-54	1/8" Hex Wrench	1
	000-0600-62	5/32" Hex Wrench	1
	000-0600-70	3/16" Hex Wrench	1
	794-8017-42	1" Combination Wrench	1
N/S	000-0601-00	1/4" Hex Wrench	1
30	000-0170-60	Wheel Mounting Bolt, 2.75"	1
31	000-0170-55	Wheel Mounting Bolt, 2.50"	1
32	000-0170-35	Wheel Mounting Bolt, 1.25"	1
33	000-0170-27	Wheel Mounting Bolt, 1.00"	1
34	794-8013-12	O-Ring	1

STANDARD EQUIPMENT — FG5000/ FG10000



2 qt of Table Lube
1 qt of Coolant Additive

Descriptions of above items are on the previous page.

TOOL BOARD ASSEMBLY (794-8688-04)

PART #	DESCRIPTION	QTY
000-1145-02	Wrought Iron Washer Zinc Plated	2
000-8000-91	Wood Dowel Pins inserted into bottom back of board	2
794-8015-98	Mounting Screw, .25 X 20 X 1.5"	2
794-8688-03	Main Tool board base with dowel pegs (small shelf sold separately below)	1
794-8044-43	Tray Assembly with mount screws (Sold Separately)	1

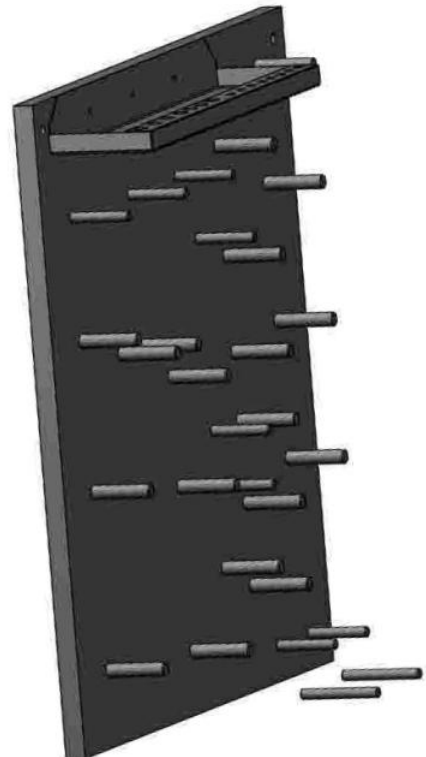

A new flywheel grinder comes with a complete tool board and tray ready to be mounted on the side of your machine. These items are listed here in case replacement parts are ever needed.

COMMON OPERATING SUPPLIES

(A listing of commonly re-ordered items for machine operation)

PART #	DESCRIPTION	QTY
794-8010-64	Centering Cone Bolt 1.88" (47.6 mm)	1
794-8010-65	Centering Cone Bolt 2.375" (60.3 mm)	1
794-8010-66	Centering Cone Bolt 3.375" (87.8 mm)	1
794-8010-67	Centering Cone Bolt 3.5"(88.9 mm)	1
794-8011-40	Coolant Additive, 1 Qt. (.946 liter)	1
794-8011-41	Coolant Additive, 1 Gal. (3.8 L)	1
794-8011-42	Coolant Additive, 5 Gal. (18.9 L)	1
794-8017-44	E-Z Lock Inserts	1
794-8017-45	E-Z Lock Inserts (5 pack)	1
794-8011-55	Table Lubricant, 1 qt. (.946 liter)	1
794-8011-52	Leadscrew Lubricant	1

GRINDING WHEELS

794-8011-12	Grinding Wheel 6" Flaring Cup (for harder metals)	1
794-8011-30	Grinding Wheel 6" Flaring Cup (general purpose formula)	1
794-8011-28	Grinding Wheel 4" Flaring Cup	1
794-8687-01	Grinding Wheel 3" Flaring Cup (Requires 794-8686-97 Mounting Flange)	1
794-8030-00	CBN Wheel 3" Formula X (Requires 794-8686-97 Mounting Flange)	1
794-8040-00	CBN Wheel 3.75" Formula X	1
794-8060-00	CBN Wheel 6.0" Formula X	1

The Unique Table Design

The Van Norman Flywheel Grinders use a “floating” table design as illustrated above. The vast majority of the downward force is displaced over a large pool of special lubricating oil. This allows the table to be rotated without much force and eliminates deflection. No need to replace table bearings and you can grind with closer tolerances and greater pressures.

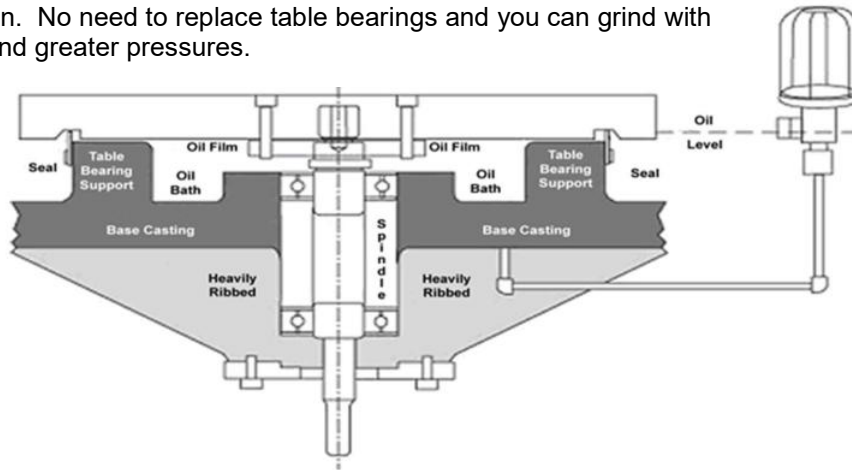

FG5000 Pictured, FG10000 has same footprint but is 3" Taller

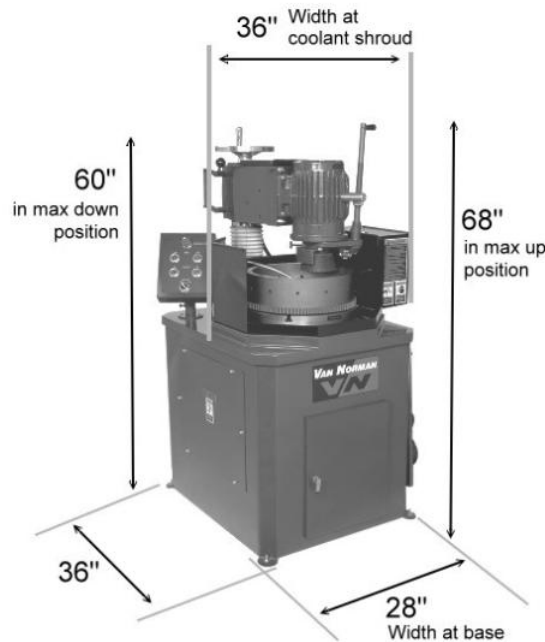

Note: When installing near interior walls, allow enough room to gain access to service panels on the side and rear of the machine.

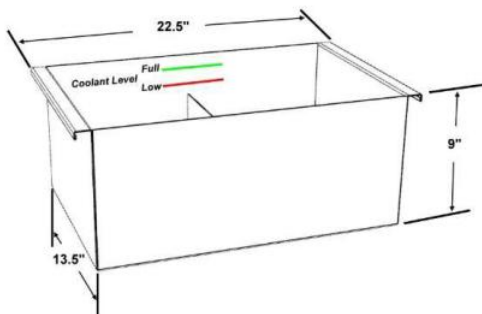

Coolant Tank

13.5" wide x 9" high x 22.5" deep

IMPORTANT: Notice the full and low coolant levels. There must ALWAYS be coolant flowing over the baffle panel or the pump WILL burn out from overheating.

BEGIN OPTIONAL EQUIPMENT SECTION

(Optional Kits and Equipment for Expanding your Grinders Abilities)

794-8625-27 Radius Cutter Assembly

PART #	DESCRIPTION	QTY
794-8084-05	Boring Bar, 1.5" (38.1 mm) Dia.	1
794-8084-06	Boring Tool – Carbide	1
794-8011-99	Spacer, Power Column Washer (3)	3
794-8621-28	Mounting Plate	1
794-8084-07	Socket head Set Screw cup point 5/16" 18X.500	1
794-8030-20	Hex Head Cap Screw .500-13X1.75 5	3
000-1150-53	1/2 Washer – Zinc Plated	3
000-0170-27	3/8-16X1 Socket. Head. Cap Screw	2



VAN NORMAN MITEE BITE KIT (HOLD DOWN TOOLING): 794-8684-93



Mitee Bite Clamp Kit includes 4 hex stools.
Resurfaces all sizes of floater plates. The Mitee Bites, which are .250" tall, restrict movement of plates. The Mitee Bites are positioned in the 3 T-slots on the table.

Note: Individual pieces from the Mitee-Bite kit are not sold separately.

Optional Light Assembly (794-8685-50)



PART#	DESCRIPTION	QTY REQ
000-1118-28	3/8 Metal Conduit Locknut	1
000-1241-41	30-072 (72-B) Wire Nut-BL	2
000-1252-18	Flexible Task Lamp	1
000-2410-24	Elec. Wire 16GA Black-MTW	12.5
000-2410-75	Elec. Wire 16GA White-MTW	12.5
001-1601-76	LED 115v Light Bulb	1
794-8048-43	Terminal 16-14 GA	2

NOTE: Light Assembly attaches to the existing electrical box located on the grinding motor.

WARNING: Always disconnect machine from its main power source before attaching anything to the grinding motor other than a proper grinding wheel.

794-8627-83

DIAL INDICATOR / INDICATOR BAR SET

ITEM	PART #	DESCRIPTION	QTY
in 10	000-0485-10	¼-20X¼ SOC CUP PT SS	1
11	001-0023-75	0 – 1 INCH DIAL INDICATOR	1
In 10	794-8013-17	MOUNTING ADAPTER	1
10	794-8013-20	INDICATOR BAR	1
9	794-8013-21	SPACER 13/32 X ¾ X 2 ¼	1
1	794-8013-22	CONVEX POINT	1
12	794-8013-24	INDICATOR BAR ASSY.	1
8	794-8055-99	3/8 16 X 3 ¼ SOC HEAD CAP SCREW	1
7	794-8627-82	DIAL INDICATOR MAGNETIC BASE	1
13	000-1020-16	¼ 28 HEX JAM NUT	2
2	794-8011-91	KNOB FL .734 PL KRL .25	1
3	794-8013-33	POINT INDICATOR 1.00	1
4	794-8017-04	ASSY, INDICATOR EXTENSION	1
5	794-8013-30	FOOT LEVELING .500 DIA	1
6	794-8020-53	FOOT ASSEMBLY 1.00	1

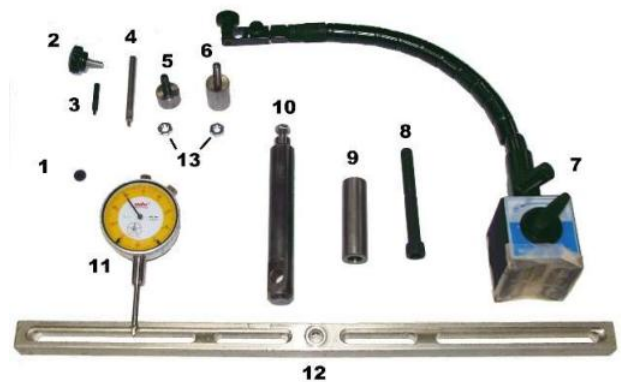

794-8685-32 WHEEL TILT SETTING KIT

(Included in 794-8627-83 Dial Indicator / Indicator Bar Set Above)
This kit is minimum requirement for Head Tilt Adjustment on Page 18

Item	Part #	Description	QTY
	794-8013-17	Mounting Adapter (not shown)	1
1	001-0023-75	Dial Indicator	1
2	794-8013-20	Indicator Bar	1
3	794-8013-21	Spacer	1

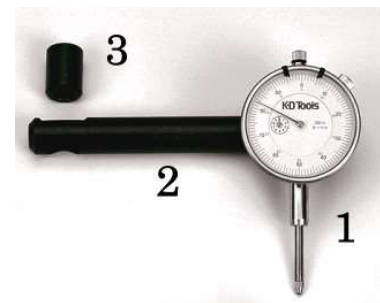

794-8692-67 STEP COMPARATOR KIT

Item	Part #	Description	QTY	Item	Part #	Description	QTY
1	794-8692-68	Indicator Bar	1	5	794-8692-69	1.00" Standard	1
2	794-8013-19	Dial Indicator	1	6	794-8692-82	2.00" Standard	1
3	794-8017-04	Truck Extension (2.50")	1	7	794-8011-91	Hand Knob	1
4	794-8013-33	Automotive Ext. (1.00")	1				

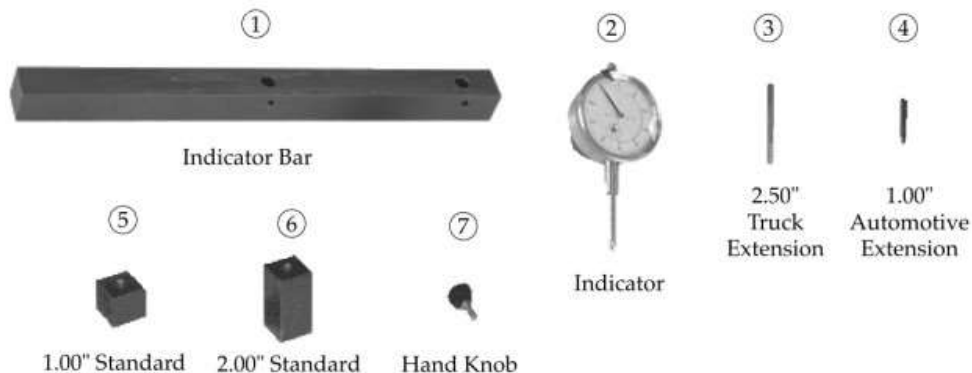

794-8627-82 Dial Indicator Magnetic Base

(Included in 794-8627-83 Dial Indicator / Indicator Bar Set Previously Shown)

Part #	Description	QTY
794-8627-82	Dial Indicator Magnetic Base Allows for easy positioning of the Dial Indicator, sold separately.	1



794-8107-90 Small Bore/VW Centering Cone Set

ITEM	PART #	DESCRIPTION	QTY
1	794-8010-69	VW Rabbit Centering Cone, 1.38"	1
2	794-8010-70	Centering Cone, 1.375"	1
3	794-8010-95	VW Flange Adapter	1
4	794-8015-96	FSHCS, .437-14 x 2"	1
5	794-8016-28	SHCS, .437-14 x 1.5"	1
6	794-8686-99	FSHCS, .437-16 x 2.50"	1
7	794-8687-14	SHCS, .437-14 x 2.25"	1



794-8107-88 HD Universal Centering Cone & Spacer Set

ITEM	PART#	DESCRIPTION	QTY	ITEM	PART#	DESCRIPTION	QTY
1	794-8010-58	Tee Nut .375-16 x .500 (3)	3	8	000-0170-94	SHCS .375-16 x 2.25	1
2	794-8010-59	Hex Stool, 0.5" (12.7 mm) (3)	3	9	000-0170-19	SHCS .375-16 x .75 (3)	3
3	794-8687-12	Hex Stool, 1" (25.4 mm) (3)	3	10	000-0170-35	SHCS .375-16 x 1.25 (3)	3
4	794-8010-82	Centering Cone, 4" (101.6 mm)	1	11	000-0170-51	SHCS .375-16 x 2.00	1
5	794-8010-84	Centering Cone, 4.5" (114.3 mm)	1	12	794-8055-99	SHCS .375-16 x 3.25	1
6	794-8010-86	Centering Cone, 5" (127.0 mm)	1	13	000-0170-65	SHCS .375-16 x 3.00	1
7	794-8011-89	Wheel Spacer, 1" (25.4 mm)	1	14	794-8677-99	Centering Cone Bolt, 4.25"	1
					794-8011-90	Wheel Spacer, 2" (not shown)	1

794-8684-78 Dowel Pin Kit

Popular Automotive Domestic and Import Kit

ITEM	PART#	DESCRIPTION
1	794-8688-44	Slide Hammer
2	794-8688-45	Slide Rod
3	794-8688-46	Tightening Sleeve
4	794-8688-56	1/4" Collet (6.35mm)
5	794-8688-57	5/16" Collet (7.93mm)
6	794-8688-58	3/8" Collet (9.53mm)
7	794-8688-59	7/16" Collet (11.10mm)
8	794-8688-62	5mm Collet
9	794-8688-63	6mm Collet
10	794-8688-47	Removal Stand
11	001-1001-57	Storage Case



794-8684-77 0-4" Optional Micrometer (not shown)

Optional Collets

794-8688-55	3/16" Collet (4.75mm)	794-8688-61	4mm Collet
794-8688-60	1/2" Collet (12.7mm)	794-8688-64	8mm Collet
794-8688-89	9/16" Collet (14.28mm)	794-8688-65	10mm Collet

794-8680-18 Heavy Duty Centering Adapter Set

ITEM	PART #	DESCRIPTION	QTY
1	794-8657-37	Ford/Cat 205, 2.040" (51.8 mm)	1
2	794-8657-38	Mack 305, 2.435" (61.8 mm)	1
3	794-8657-39	Ford Truck, 2.495" (63.4 mm)	1
4	794-8657-40	Cum/GMC 306, 2.830" (71.9 mm)	1
5	794-8657-41	Ford 307, 3.149" (79.9 mm)	1
6	794-8657-42	Ford Truck, 3.255" (82.7 mm)	1
7	794-8677-99	4.25" Centering cone bolt assembly	1

CENTERING CONES FOR SPECIFIC COMMON ENGINE MODELS

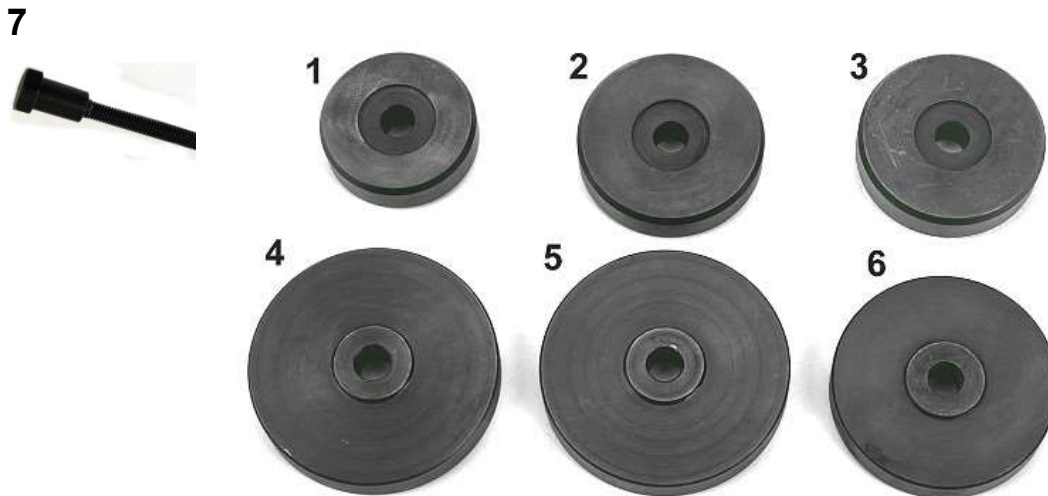

HEAVY DUTY TRUCK ROTOR KIT



794-8628-00

RESURFACE LARGE TRUCK ROTORS ON YOUR FG5000 OR FG10000 WITH THIS KIT.

Fire Trucks, Ambulances, and all kinds of other service and construction vehicles can now have their brake rotors resurfaced by you using your FG5000 or FG10000!

Item	Part #	Description	Item	Part #	Description
1	794-8060-00	6" CBN Formula X Wheel	8	804-7803-01	Arbor Spacer 3.00"
2	794-8628-23	Alignment Pin Assembly	9	804-7803-05	Arbor Spacer 2.00"
3	794-8692-39	SC HD CS 3/8-16X4.25	10	804-7803-02	Arbor Spacer 1.00"
4	794-8628-21	Grinding Wheel Spacer Asm	11	804-8664-59	Centering Cone 4.5-5.5
5	804-7803-35	Arbor Nut Wrench	12	804-8664-60	Centering Cone 5.0-6.5
6	794-7803-03	1-1/4"-12 Nut	13	804-8664-61	Centering Cone 5.875-7.375
7	794-8628-27	Mounting Washer	14	804-8664-62	Centering Cone 6.875-8.125



Huge Additional Profit Potential!

MACHINE DESCRIPTION

1. Emergency Stop
2. Table On/Off
3. Grinder Motor On/Off
4. Coolant Pump Switch
5. PowerHead Up/Down
6. AutoGrind™ On/Off
7. AutoGrind™ Grinding Rate
8. Coolant Pump/Reservoir Access
9. Table
10. Coolant Nozzle
11. Grinding Wheel
12. Grinding Motor
13. Column Lock Handle
14. Micrometer Feed Dial (rear top)
15. Wheel Dresser
16. Fine Feed Hand Knob
17. Manual Feed Hand Wheel

(Switch Part Numbers start on page 33)

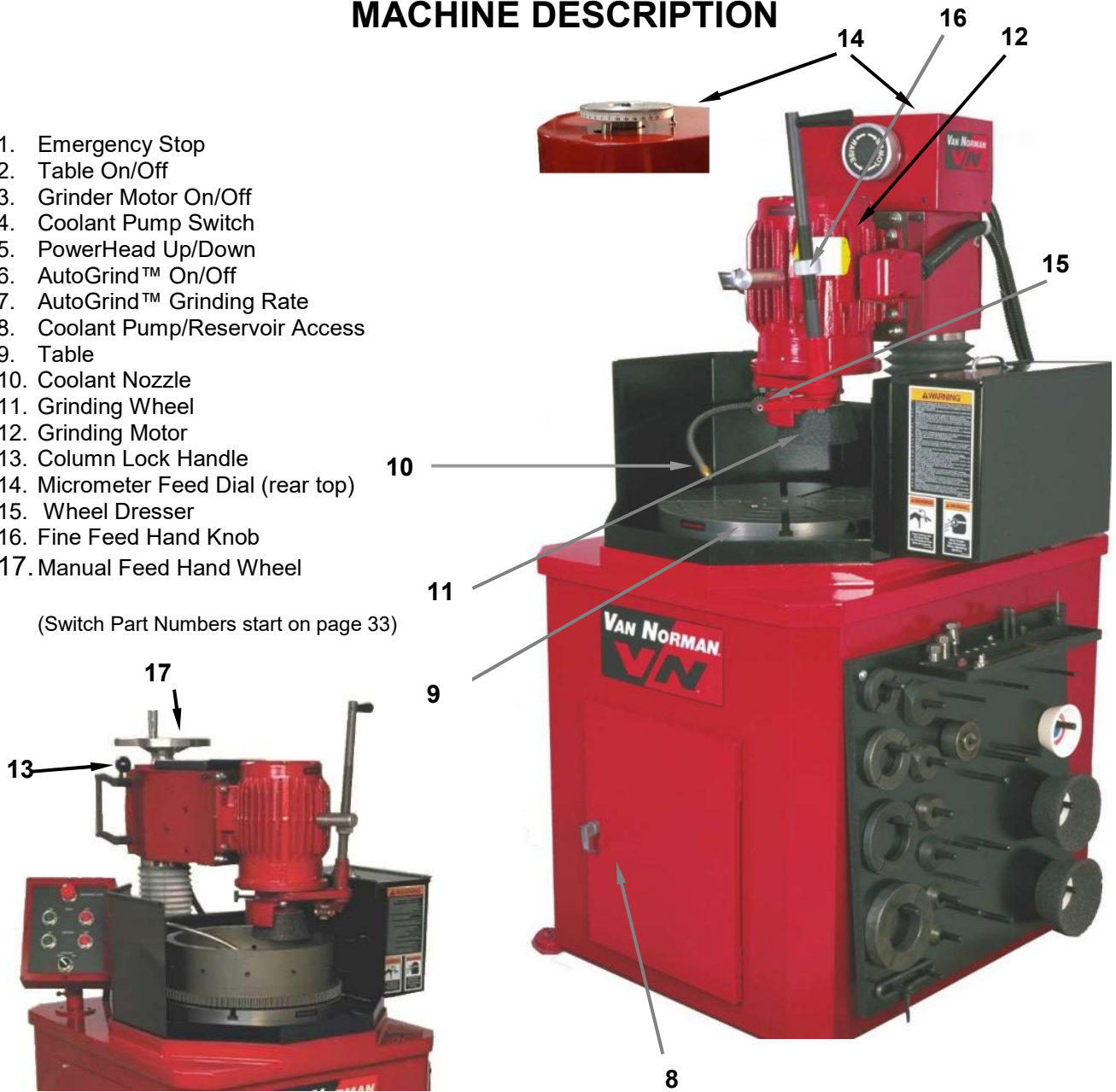

Standard Controls

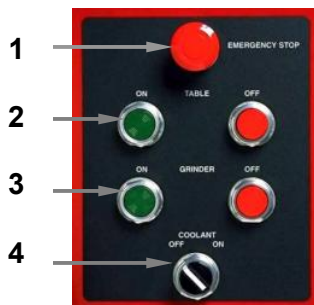

PowerHead Control



PowerHead with AutoGrind™ Controls



MACHINE SET-UP

1. Remove protective covering from around machine. Remove bolts from four corner pads to free machine from skid. Remove all tooling packages from machine and set aside. Using the fine feed hand knob, raise the grinding head motor off the wood shipping block and discard. Unlock the grinding head column lock handle (Figure 1) and swing the grinding head motor so it is centered over the table. Relock the motor flange.
2. A forklift is recommended for removing the machine from the skid and setting in place. Lift only from the base cabinet **from the rear** (Figure 2).



Figure 1

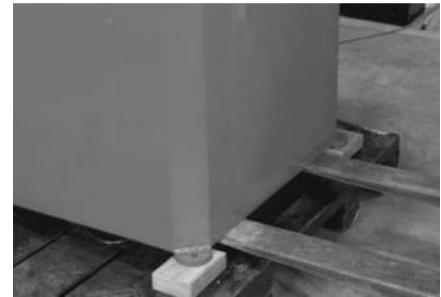

Figure 2



Rear



Figure 3

3. Locate machine in desired area. Install leveling bolts, lock nuts and leveling pads in each corner of the machine (Figure 3). Place a level on the table (Figure 4). Level the machine side-to-side and front to back adjusting the four leveling bolts. This is best done by leveling diagonally in parallel with the corners of the cabinet. Tighten lock nuts when level.

IMPORTANT: The machine **MUST BE LEVEL** to operate correctly and on solid ground.

4. Remove rust preventative from machine using an approved commercial solvent.



Figure 4

FG5000/FG10000 Flywheel Grinder

1. Unpack tool board and install the 2 - wooden pegs on the bottom of the backside of the tool board. This sets the tool board at a slight angle when mounted on machine. Install the tool board on right side of machine using the 2 - 1/4" screws provided. Next, screw the tool tray to the top of the tool board using the 3 - screws provided (Figure 5).
2. Unpack the Standard Tooling, clean with an approved commercial solvent, and place on the tool board.
3. Install the plastic handle in wheel dresser (Figure 6)

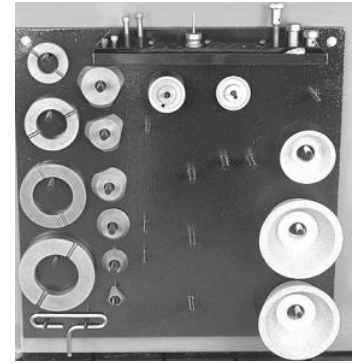

Figure 5

FILL OIL RESERVOIR

1. Remove the large flat head cap screw from the machine table (Figure 7). Add approximately one quart Table Lubricant (P/N: 794-8011-55) to the reservoir through the filler hole (Figure 8) and replace cap screw. Make certain the small O-ring is in place on the underside of cap screw.
2. Remove the plastic oil container at the rear of the machine from its base by turning counterclockwise (Figure 9). Invert the container and fill with Table Lubricant 794-8011-55 through the bottom tube. Quickly invert and re-install the oil container, tighten hand tight only.



Figure 6

After installation, the oil level in the plastic container will start to drop. The base of the oiler has been preset at the factory to the proper height. When the oil level in the reservoir in the base casting reaches the preset height the level in the plastic container will stabilize. It may be necessary to refill the container after level has stabilized.



Figure 7

NOTE: Avoid large air bubbles in the tubing between the plastic oil container and the table. Tubing is located under the deck casting.



Figure 9



Figure 8

FG5000/FG10000 Flywheel Grinder

3. A depth gage is provided with the machine for checking the oil level through the hole in the table that is capped with a hex screw (Figure 10 and 10A). The overall length of the gage pin should be set to equal the thickness of the machine table (Figure 10B). Set pin to bottom of table and tighten setscrew on side of gage (Figure 10C). The oil level line marked on the gage pin is 1/16" above the bottom of the table.
4. In the center hole of the table is a 7/16"-14 set screw. This was installed during shipping of the machine to keep any debris out of the hole. Remove set screw and discard.



Figure 10

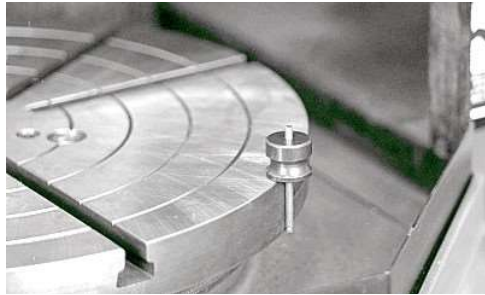

Figure 10B



Figure 10C



Figure 10A

FILL COOLANT TANK

Open front access door and slide coolant tank out of machine (Figure 11). Pour one quart of (P/N: 794-8011-40) Coolant Additive into the tank and add water to within approximately one inch of the top. Slide coolant tank back into machine. Direct coolant drain hose to the inside of the tank. After machine is wired, turn on coolant pump and set flow by turning valve located outside the sheet metal coolant shroud (Figure 12).

CAUTION:

Excessive buildup of grinding sludge in the coolant may cause premature failure of the coolant pump. Clean out coolant tank every 25 flywheels or more frequently as needed.



Figure 12



Figure 11

MACHINE ELECTRICAL CONNECTION

1. A qualified electrician should do the electrical hookup to your new machine. The power source supplied must be the same as specified on the Serial Plate, which is attached to the motor flange (Figure 13).
2. Connections are made at the fuse block located inside the electrical box mounted on the side of the machine. Refer to the diagram for a three-phase hookup (Figure 14) and a single-phase manual mach. hookup (Figure 15). Please note that single-phase non-manual machines require a 4-wire hookup; which includes 2 wires to hot, 1 wire to ground and 1 wire to neutral. These machines will not operate without the neutral connection.



Figure 13

On **Single Phase Non-Manual Machines** the common wire must be connected to the bottom right of the main terminal block.

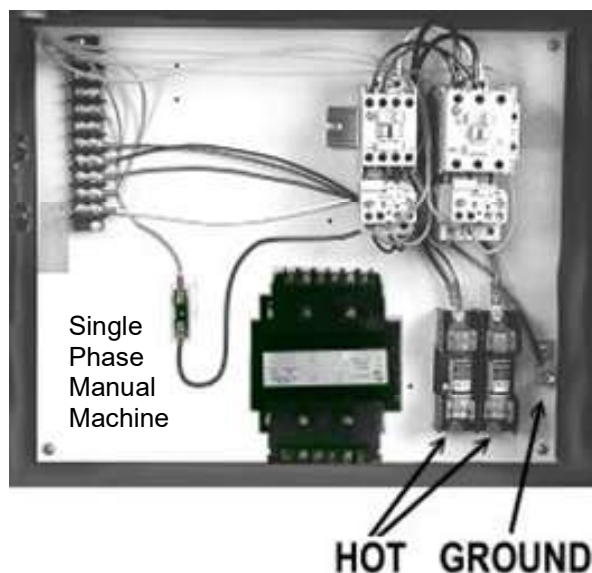
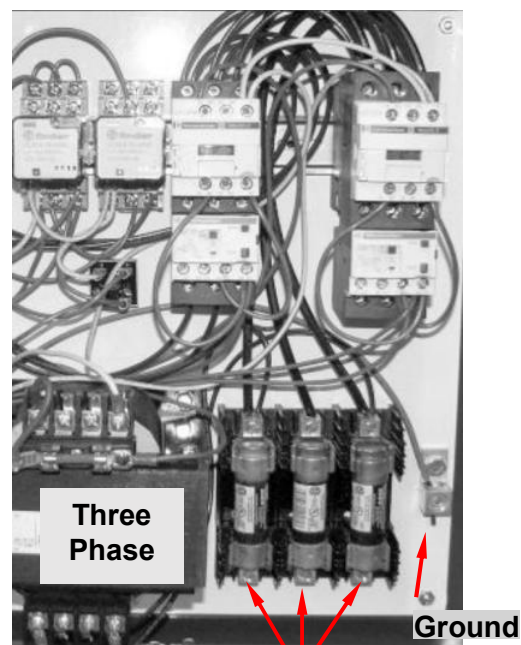

Figure 15



Hot
Figure 14

3. After the electrical hookup is completed, verify correct rotation of the table and grinding motor.
4. Turn on table motor. Table should rotate in counter clockwise direction when viewed from the top (see arrow label on edge of table). Turn on grinding motor. Motor should rotate in clockwise direction when viewed from the top (see arrow label on front of motor)
5. If both the table motor and the grinding motor are rotating the wrong direction, interchange any two of the three HOT LEADS of the 3 Phase connections at the electrical box (Figure 14). DO NOT INTERCHANGE THE GROUND WIRE. If the rotation is correct on one motor, but not the other, contact Van Norman technical assistance.
6. On 1 Phase (Single Phase) machines, if rotation is not correct, contact Irontite Support for assistance.

OPERATION

1. Remove the coolant shroud door at the front of the machine using the two handles. Select a grinding wheel according to the material to be ground. (See grinding wheel selection, Page 11)
2. Install the grinding wheel (Figure 16) Tighten to 150 In. Lbs. Occasionally it may be necessary to use a wheel spacer in order to reach to the bottom of a recessed flywheel. Use the spacer and the longer cap screw provided and install (Figure 16).
3. When a new grinding wheel is installed, or a wheel is re-installed, the wheel should be dressed or “trued up” (Figure 17).



Figure 16

CAUTION: DO NOT INSTALL GRINDING WHEEL IF EITHER OR BOTH PAPER BLOTTERS ARE MISSING.

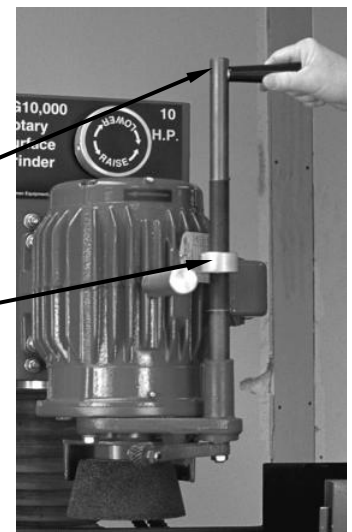

Wheel Dresser

WHEEL DRESSER

Adjustment Collar

1. Since it may be impossible to accurately match the grinding wheel material and hardness to the metal alloy being ground, it may become necessary on some applications to dress the grinding wheel after use. The purpose in dressing the wheel is to remove that portion of the wheel's edge that has become dull and/or clogged with particles causing a decrease in cutting ability. A clean grinding wheel will be evident and very little heat will be generated in the work piece. Under ideal circumstances, the grinding wheel will break down during grinding at a rate sufficient to keep sharp. Clean particles exposed on the grinding edge. If the grinding rate decreases noticeably as evident by a decrease in the shower of sparks, it will be necessary to dress the wheel. This should be accomplished by raising the wheel up far enough so that the dresser can swing under the wheel. The dresser height is changed by rotating the adjustment collar (Figure 17).
2. Adjust wheel guard and install shroud door for maximum protection. (No coolant is needed for the dressing operation). Start grinding motor. Carefully swing the dresser back and forth under the front edge of the grinding wheel, gradually rotating the dresser adjustment collar to raise the dresser until contact is made. Only a small amount of material has to be removed to obtain a new grinding edge.

Figure 17

SETTING UP THE FLYWHEEL

1. To load the flywheel, remove the front coolant shroud door, raise the headlock handle and swing the grinding head into the far right hand corner of the shroud, flipping the shroud cover out of the way (Figure 18).
2. A cross section diagram of the general method for setting up a flywheel for grinding is shown in (Figure 19). Detailed instructions are outlined below. The accuracy of the ground flywheel will depend to a large extent on the accuracy and condition of the surface that the flywheel is mounted on. A flywheel cannot be expected to run true if it was ground on a surface that was not parallel to the Crankshaft mounting surface. Whenever a flywheel is ground while mounted on a surface other than the Crankshaft mounting surface, careful inspection to assure parallelism of the two surfaces should be done.
3. Clean the table and lay the proper flange adaptor on the table. Use the largest possible flange adaptor for maximum support. Place your flywheel onto the table with the Crankshaft mounting surface contacting the flange adaptor (Figure 20).
4. Choose the proper sized centering cone to fit the center hole in the flywheel. (Figure 21) Select the correct length of centering cone bolt. Secure your flywheel to the table by tightening the centering cone bolt. If exact centering is necessary such as on some recessed flywheels, a dial indicator may be used to insure accuracy.
5. Position grinding wheel over friction surface to be ground and lock grinding head in place by pulling headlock handle on left side of head downward.

POSITION WHEELGUARD FOR MAXIMUM OPERATOR PROTECTION.

6. Replace shroud cover and actuate grinder motor, table motor and coolant pump. Direct Coolant onto the work piece so it flows under the grinding wheel. Regulate the amount of coolant flow by adjusting the valve on rear of shroud.

NOTE: NEVER GRIND WITHOUT ADEQUATE COOLANT FLOW, and avoid directing coolant under the table edge.



Figure 18

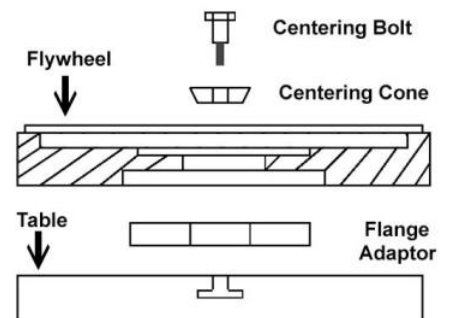

Figure 19

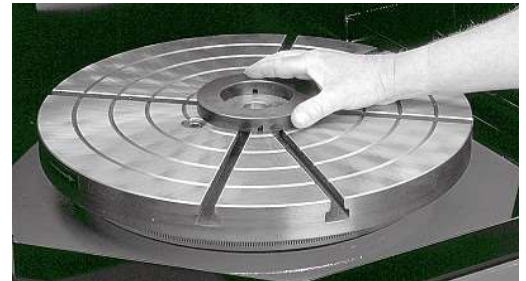

Figure 20



Figure 21

GRINDING FLYWHEEL

MANUAL MACHINES:

Feed grinding wheel downward by turning feed handle clockwise (Figure 22). Grind surface until flat and free of defects or to desired depth.

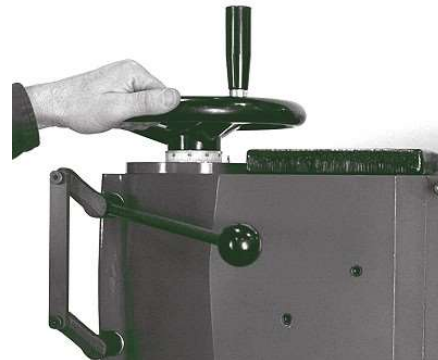

Figure 22

POWERHEAD MACHINES:

1. Power the grinding head down to the work piece using the power column up/down switch (as a safety feature, the power column will not function if the grinder motor is running).
2. Start table, grinder head motor, and coolant flow.
3. Rotate the fine feed hand knob clockwise (Figure 23) to lower grinder head until stone contact is made. (if machine is equipped with the auto grind feature, proceed to step 4) Continue to feed grinder head down to grind surface until flat and free of defects or to desired depth.



Figure 23

4. This step is for machines equipped with auto grind only:
 - a. Determine depth of grind (amount of material to be removed).
 - b. Rotate graduated dial to that amount lined up with pointer (Figure 24)
 - c. Select the down feed rate with the variable feed rate dial.
 - d. Start to auto grind by depressing the "on" switch.
 - e. Auto grind will stop feeding and turn off when the preset depth is reached (feed may temporarily stop as it senses the grinder motor being overloaded and then restart automatically during the auto grind process until finished).
 - f. Turn off table, grinder head motor, and coolant after the work piece sparks out.



Figure 24 - Power Column

SURFACE FINISH: Keep the grinding wheel cutting at all times never allow the wheel to coast for a long period of time without feeding it downward. Long periods of coasting will cause the grinding wheel to glaze and load up. The only exception to this is when it is desired to obtain a very smooth finish. A wide variety of surface finishes are obtainable using the grinder without varying the grit size of the grinding wheel. This range of surface finish is obtained by varying the pressure exerted on the grinding wheel. A coarse finish is obtained by feeding heavily then backing off the work piece quickly. Smoother finishes are obtained by backing off the work piece then coming back down with a very light feed pressure.

FG5000/FG10000 Flywheel Grinder

RECESSED FLYWHEELS: When grinding recessed flywheels, the depth dimension from the pressure plate mounting surface to the clutch friction surface should be restored after grinding of the friction surface. This is done by grinding the pressure plate mounting surface an amount equal to that ground off the friction surface. The steps followed in grinding recessed flywheels are as follows:

- a. Mount flywheel on machine.
- b. If original equipment specs are unavailable, use a depth micrometer to measure depth from pressure plate mounting surface to an unworn area of the clutch friction surface.
- c. Grind friction surface to clean up.
- d. Use depth micrometer again to measure new depth. Subtract original depth from this measurement to obtain amount to be removed from pressure plate mounting surface.
- e. Locate dial indicator on pressure plate mounting surface, set dial to zero.
- f. Grind surface until dial indicator reading changes by the proper amount.

While a dial indicator or a depth micrometer is used to measure a specific amount of material, the graduated dial (Figure 24 – Power Column and Figure 25 – Manual Machine) will give the operator an **approximate** amount of material removal. The readings of this dial will be influenced by both stock removal and wheel wear.

RADIUS CUTTER OPERATION (OPTIONAL)

Before grinding the flywheel or cutting a radius on a recessed flywheel, make certain the flywheel is accurately centered. A dial indicator may be used. It is not necessary to use coolant when using the radius cutter

1. On certain applications on a recessed or stepped flywheel such as International, Mack, etc., it is necessary to remove the slight radius left by the grinding wheel. This can be accomplished using the optional Radius Cutter (Figure 26).
2. First, adjust the radius cutter assembly so the cutting tip of the tool bit is positioned over the center of the table. This can be done by loosening the 3 hex bolts that attach the radius cutter to the machine (Figure 26A) and sliding the assembly to the front or back and retighten.
3. The tool bar may be positioned to the correct depth by loosening the 2 cap screws (Figure 26B) and sliding the bar up or down and retighten. When properly positioned, the grinding wheel will be about 1/2" above the highest point of the flywheel when the tool bit is in contact with the radius to be removed. Do not over extend the tool bar.
4. Loosen the column lock handle. Swing the grinding head to the left side of the flywheel, so the tip of the tool bit is at its outermost location. Gradually feed the grinding head down until the radius is removed.



Figure 24 - Power Column

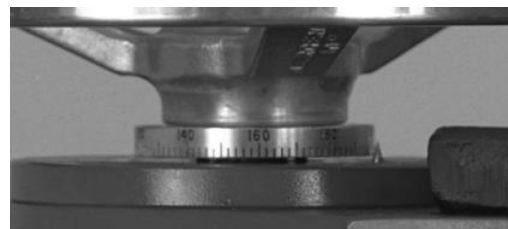

Figure 25 - Manual Machine

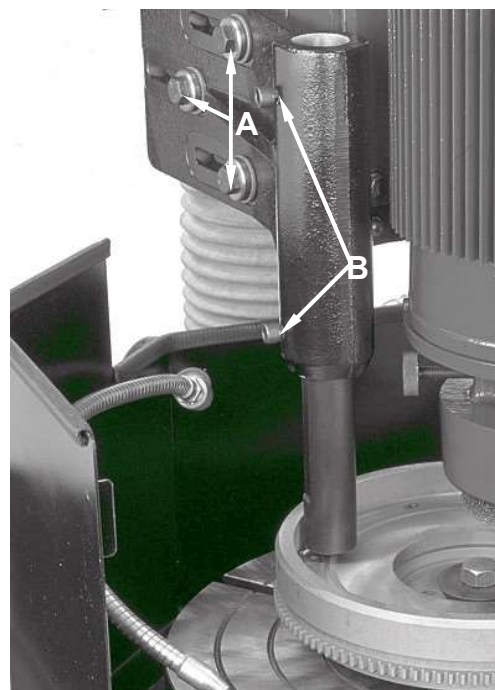

Figure 26

Lubrication

1. **Table Support Bearing:** The turntable is completely supported from below by a cast in table support. The table runs on a film of oil supplied by the reservoir in the center of the base casting. The level of this reservoir is adjustable and must be approximately 1 /16" above the surface of the table bearing (or the bottom of the table). This level has been pre-set at the factory and should not require further adjustment. (Figure 27). Use 794-8011-55 Table Oil only. (see note below.)
2. The level of the oil under the worktable is checked by removing the large flat head cap screw from the table. A depth gauge is provided with the machine for checking the oil level through this hole in the table. The overall length of the gauge pin protruding from the round handle should be equal to the thickness of the machine's table (Figure 28). The oil level therefore, will be 1/16" above the bottom of the table.
3. The plastic oil reservoir at the rear of the machine should be refilled with Table Lube Oil when it reaches 1/4" from the bottom. **Use only part number 794-8011-55 Table Lubricant.**
4. **COLUMN**
The main column is lubricated from the same plastic oil reservoir. As long as oil is in this container both the table bearing surface and the column will be adequately lubricated. You may need to adjust the flow of lube to the back of the column if you see lube on the floor in the rear of the machine.
5. **LEADSCREW AND NUT**
Lubricate the Leadscrew and bronze nut as required to maintain smooth operation with 794-8011-52 Leadscrew Lubricant or a medium duty grease containing graphite or molybdenum.



Figure 27



Figure 28

NOTE: Table movement failure while under a load is most likely due to a lack of table lube or use of a non-approved lubricant. You may need to refill or change the height adjustment of the clear bottle in the right rear corner of the cabinet top to help prevent running low on table lubrication.

GRINDING MOTOR

CAUTION: Over greasing bearings can cause premature bearing and/or motor failure. The amount of grease added should be carefully controlled.

NOTE: If lubrication instructions are shown on the motor nameplate, they will supersede this general instruction.

Current Grinding Motors no longer require any need to lubricate them.

POWER COLUMN GEARMOTOR

The power column gear motor is a permanently sealed unit and does not require any further lubrication.

TABLE DRIVE GEAR REDUCTION BOX

The table drive gearbox should never require additional or changing of its lubrication.

MACHINE MAINTENANCE

1. **COOLANT TANK REMOVAL AND CLEANING:** Clean Tank after every 25 flywheels
 - a. Open front access door and pull entire coolant unit completely out onto floor.
 - b. Remove pump.
 - c. Empty, clean and flush tank.
 - d. Re-install pump, slide unit half way into machine, add one quart of 794-8011-40 coolant additive and fill with water.
 - e. Slide coolant unit completely into machine.

2. **FLYWHEEL E-Z LOCK INSERT:** The table spindle into which the flywheel hold down bolts get threaded contains a threaded insert. (Image to right) This replaceable E-Z Lock insert is provided so that when the threads become damaged replacement of the entire table spindle is not necessary. It is recommended that replacement should be done before the insert's threads are completely worn out. An E-Z Lock insert extractor is supplied with the grinder (794-8637-45)

Once a month, remove the E-Z Lock insert (794-8017-44) from the center of the table, and coat the threads with an anti-seize lubricant. This will prevent the insert from becoming permanently lodged in place from rust and grit.

GRINDING HEAD ADJUSTMENTS

All grinding should be done with the rear edge of the grinding wheel. Insufficient rearward tilt as evident by sparks from both the front and rear of the wheel may result in abnormal heating of the work piece and necessitate more frequent dressing of the grinding wheel.

Experience has shown that tilting the head of the machine so that the indicator reading at the rear is .020" to .025" lower than at the front is a good starting point. Individual operators may want to increase or decrease tilt depending upon their own preferences. (Increased tilt should be used if higher stock removal rates are desired.)

NOTE: The head tilt on your grinder was set at the factory at .023" tilt to the rear.



E-Z LOCK EXTRACTOR
794-8637-45



E-Z LOCK INSERT
794-8017-44

FG5000/FG10000 Flywheel Grinder

WARNING: Always disconnect the power to the machine before performing any work on the machine other than mounting a proper grinding wheel.

HEAD TILT ADJUSTMENT

Head tilt adjustments requires the optional kit pictured on page 2 of this manual. P/N: 794-8685-32. It will not be possible to adjust your grinders head tilt without this optional kit.

FRONT TO REAR HEAD TILT ADJUSTMENT: Loosen two 7/16 cap screws (5/8 Hex) and turn the pair of socket head cap screws in or out to obtain desired tilt, (Figure 29).

Check Head tilt by attaching the Optional Dial Indicator and Mounting Hardware to the grinder motor (Figure 30). (Part Number 794-8685-32) Then lowering the head until indicator touches table. Rotate the indicator (and motor shaft) from front to back and note the direction and amount of indicator travel.

SIDE-TO-SIDE HEAD TILT ADJUSTMENT: The grinding head is also adjustable for side-to-side tilt. This adjustment will affect the flatness and/or parallelism of the ground work piece. The double configuration used between the grinder motor and the cast iron motor flange enables the motor to be mounted on the front plate, which pivots on a 1" dia. pin to allow side-to-side adjustment (Figure 31).

Adjustment may be made as follows:

- Loosen four 3/8-16 nuts (9/16 Hex) approximately 1/2 to 3/4 turn.
- Loosen adjusting screw on same side of machine as corresponds to the low side of the grinding wheel. Tighten screw on opposite side to pivot adjusting plate appropriate amount (Figure 32).
- Check side-to-side tilt using same dial indicator setup used in checking front to rear tilt above. The dial indicator reading should be identical when swung from one side to the other.

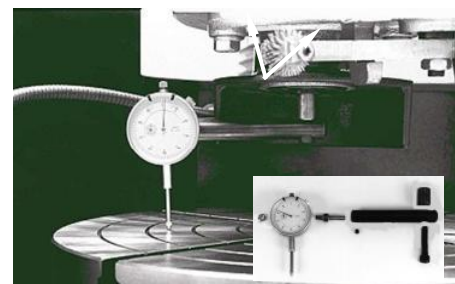

Figure 30 (optional)
Part No. 794-8685-32

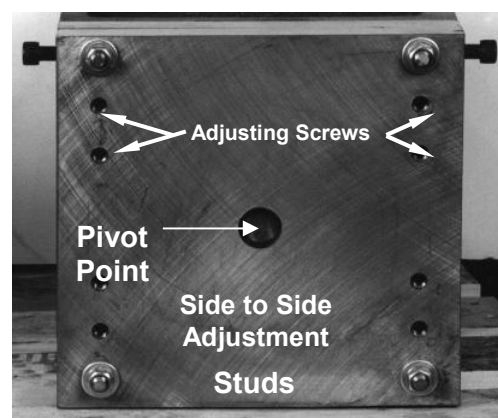

Figure 31

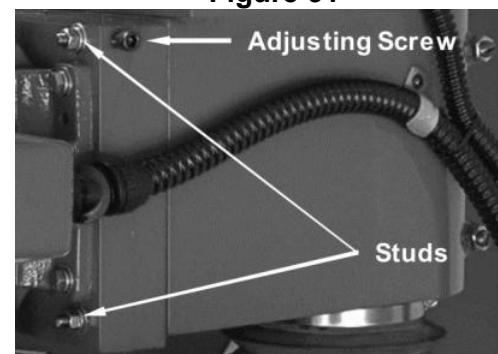

Figure 32

Head Lock Handle Position Adjustment

The locked position of the head lock handle is adjustable (Figure 33). To raise or lower the handle position follow the procedure below:

1. Loosen the 3/4 hex lock nuts.
2. With upper head lock loose, turn studs with screwdriver until handle is in desired position when the head is locked. Retighten lock nuts.

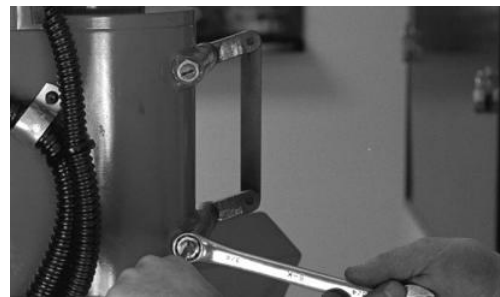

Figure 33

LEADSCREW BACKLASH ADJUSTMENT

The amount of backlash between the leadscrew and nut may be adjusted by tightening or loosening the cap screw through the bronze leadscrew nut. Access to the leadscrew nut is gained by removing the rear access door. Tightening the cap screw in the bronze nut decreases the amount of backlash (Figure 34).

= USE CAUTION TO AVOID PINCHED FINGERS OR CLOTHING BEING CAUGHT IN MOVING PARTS WHILE PERFORMING THESE STEPS =

ADJUSTMENT OF THE LEADSCREW NUT

Power Column

Lower Column to the lowest point. While raising the column, tighten the hex-key screw in the top of the leadscrew nut. Listen to the power column motor while tightening the leadscrew nut until you hear the motor begin to strain. Stop raising the column and back off the hex-key screw one quarter turn. Your leadscrew nut is now properly adjusted.

Non-Power Column

For Manual Column Machines, lower the column to the lowest point. While raising the column using the hand wheel also tighten the leadscrew nut as described above for the power column. When the leadscrew nut has been adjusted to the point that significant drag occurs, back the leadscrew nut hex-key screw one quarter turn.

Note: Do not attempt to reposition the hex-key wrench while the power column is moving. Instead, lower the column again then reposition the hex-key wrench and begin raising and tightening again. After installing a new leadscrew nut you may need to repeat this process several times until the nut is properly adjusted.

Side-to-Side Column Movement Adjustment

Any side-to-side movement noticed at the grinding head (when column is locked) can be eliminated by following this procedure.

- a) Remove access door at the rear of the machine.
- b) Lower column until the rectangular bars are in the most accessible location.
- c) Loosen jam nuts on the bolts located at the ends of both bars (Figure 35).
- d) Adjust bolts out until slight pressure is put on the round support bars. Tighten jam nuts.

Apply a film of grease on contact area of the support bars.

Figure 34

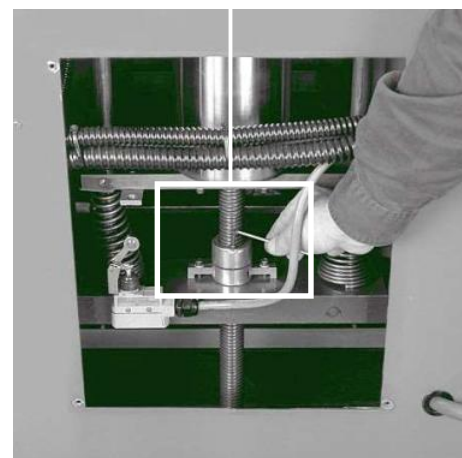
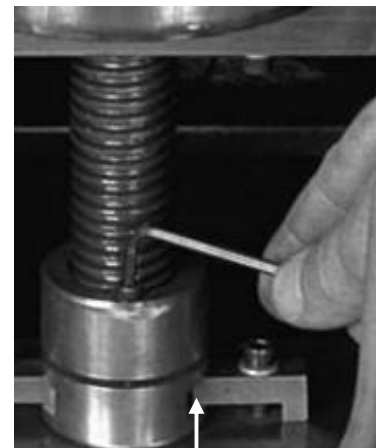

Figure 35



FG5000/FG10000 Flywheel Grinder

Head Swivel Maintenance

The When the movement of the column from side to side when not locked becomes difficult or "jerky" use the two grease zerks located on the right side of the column top section. Apply a small amount of standard automotive grease and work the grease in by moving the column top back and forth a few times.

If adding grease does not solve the problem you will need to adjust the column top. Loosen the two bolts (left hand thread) at the back of the column top and pry open slightly the casting top. Grease again and move side to side to work the grease around, then tighten up the bolts.



Best Practice for CBN Wheel Use

1. Clean the machine thoroughly, and flush the coolant system. Recharge the coolant, making sure the coolant ratio is 50 to 1 or 1 and 1/2 cups per 5 gallons of water. (One cup = 8 fluid ounces) Use KW coolant only- PN 000-2115-05.
2. Always start the grind with light down pressure, let the wheel do the work. Flood the wheel with coolant and then gradually increase the grind pressure. DO NOT overload the wheel, as premature wear will occur.
3. No truing is required. The wheel will hold its edge even after grinding in a radius on a stepped flywheel. Dressing to clean the wheel may be needed. Use appropriate dressing stone.
4. Let the wheel "Spark Out" without pressure for one to two minutes for maximum finish.

NOTE: Use caution when grinding stepped or recessed flywheels. The flywheel should be centered using a dial indicator to insure "0" radial run out.

CBN will not tolerate side impact, this will cause the wheel to break. Wheel breakage is not covered under warranty.



**CBN Wheel &
Dressing Stone
available at
kwik-way.com**



TROUBLESHOOTING GUIDE

After 30+ years of making our FG5000 and FG10000 machines we have noticed a few things that people call us about. This section is meant to try and help should you be experiencing a problem.

Grinding Motor Self Feeds

An occasional complaint for both the FG 5000 and 10000 Model Flywheel Grinders is that while grinding, the motor will "drop" or feed in on its own. There are four possible reasons for this behavior, from most common to least...

1. Feed Nut out of Adjustment - perform the split feed nut adjustment procedure. Make sure that the feed screw threads are lubricated with the correct lubricant.
2. Worn Feed Screw - the feed screw thread may be worn. Check the condition of the thread and replace if needed. If you replace the feed screw, its best practice to replace the nut and the key also.
3. Backlash at the Hand wheel - this is caused by a worn key or keyway at the hand wheel. Either the key or the part with the area where the key fits into (keyway) will require replacement. Also the bear hug nut that is a Ny-loc thread used on the power column units can rarely back off its adjustment. It will need to be re-adjusted and Loctite added to help it retain the adjustment.
4. Burrs or Scores in the Guide Rods - the head of the adjustment bolt may be gouging or digging into the guide rod which causes the column to hang up at the burr and then abruptly "drop". The burr should be removed and if severe, the rod or rods will require replacement.

As always, if this information does not solve your problem you can call 800-553-5953 for assistance from Irontite during normal business hours.

Flywheel Grinder is all stop condition

Symptom: Grinder was working fine and now nothing works. It's like someone unplugged the machine. In some cases you can press on the breaker button and everything runs but as soon as you let go it all stops.

Possible Solution: If you are certain your main power is online, then it's most likely that the 7 amp glass fuse (looks like an old automotive fuse) located almost dead center of your main circuit board has failed. Replace it and all should work once again. This fuse exists on all FG model flywheel grinders in all the various power configurations available.

If this doesn't fix the problem or if you have some motors that work while others don't, call for support at 800-553-5953. Please be sure to have your correct model number and serial number when you call.

Can't remove the E-Z Lok insert

Sometimes if the center threaded insert of your table has not been changed in a long time it will become difficult to remove. There a removal tool that came with your machine.

The E-Z Lok inserts are coated with Loctite Red which will respond to heat. So if your insert is not coming out you can use heat to help break it free.

The image on the right shows the table shaft with the table top removed. (You normally do not need to remove the table top) The insert removal tool is being inserted into an E-Z Lok insert that is half way out so you can see the Loctite Red on it.



Table Lube Leaking From the Column

The easiest way to solve this issue is to add a valve in the line to reduce the flow of oil. This has happened because the felt strip in the column base has either separated or curled and now is allowing too much lube into the column. Putting a valve on allows you to slow or even deny the oil flow.

PN: 000-1563-68



ASSEMBLY DRAWING

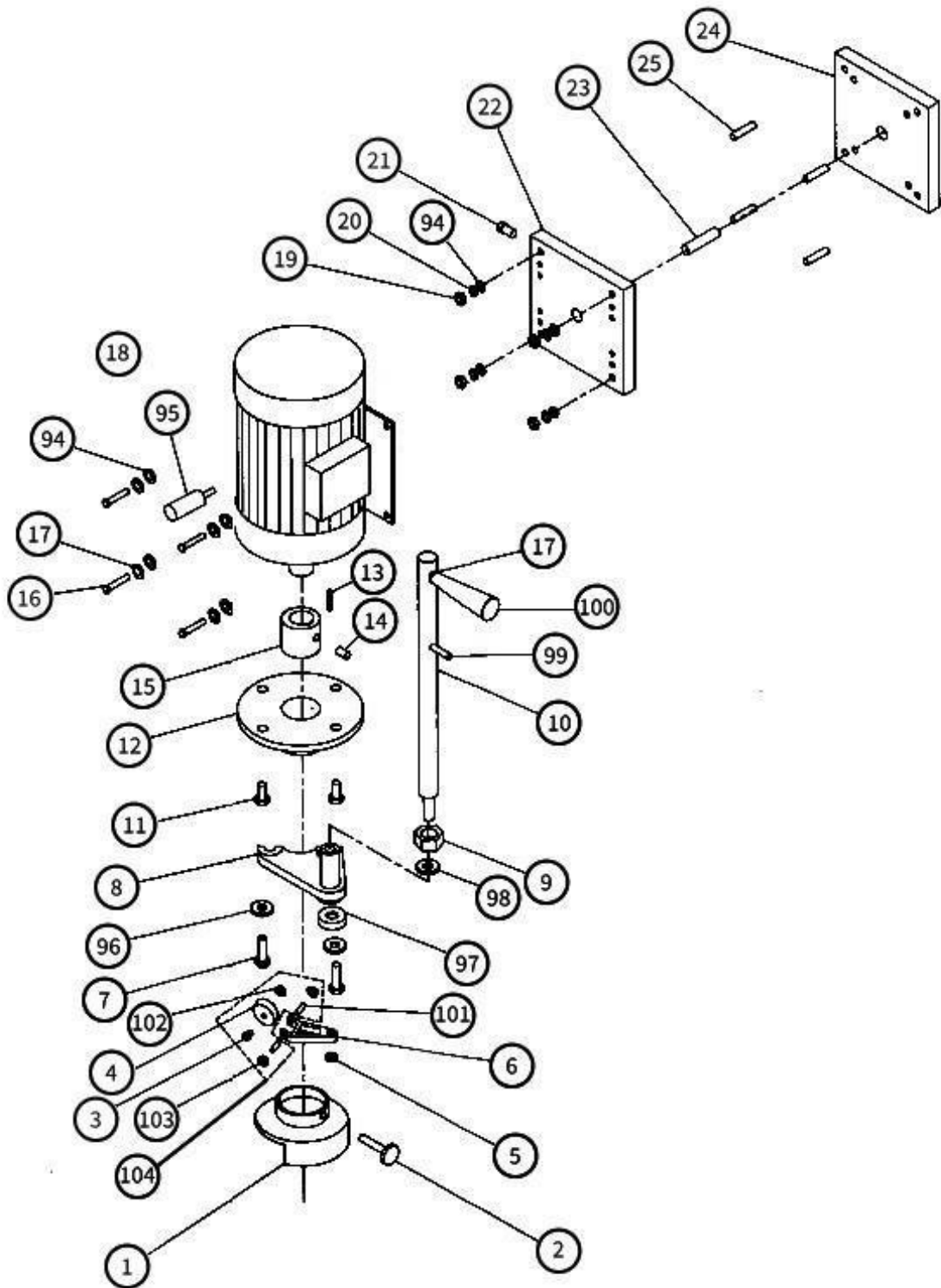

FG5000/FG10000 Flywheel Grinder

ASSEMBLY DRAWING

ITEM	PART #	DESCRIPTION	QTY	
1	794-8011-84	Wheel Guard Ring	1	
2	800-8017-30	Clamp Bolt	1	
3	794-8016-47	Star Dresser Hub	1	■
4	794-8011-69	Wheel Dresser Star	7	■
5	000-1070-18	1/2-20 Jam Nut	1	■
6	794-8011-62	Dresser Arm	1	■
7	000-0110-37	HHCS 1/2-13 x 2.00	2	
8	794-8011-68	Dresser Bracket	1	■
9	794-8011-63	Adjustment Collar	1	■
10	794-8011-64	Dresser Shaft	1	■
11	000-0114-01	HHCS 1/2-13 x 1.00	2	
12	794-8011-82	Wheel Guard Flange	1	
13		Key (Supplied W/ Motor)	1	
14	000-0485-10	Soc Cup Pt SS 1/4-20 x .25	1	
15	794-8011-87	Wheel Flange	1	
16	000-0105-53	HHCS 3/8-16 x 1.25	4	
17	800-8030-61	Lock Washer 3/8	5	
18	794-8660-97	Motor, 5 HP 208-230/460 3Ph	1	
18	794-8660-98	Motor, 5 HP 208-230/460 1Ph	1	
18	794-8687-57	Motor, 10 HP 208-230/460 3ph	1	
19	000-1035-19	Hex Nut 3/8-16	4	
20	800-8030-61	Lock Washer	4	
21	794-8649-38	SHCS 3/8-24 x 1.25	2	
22	794-8011-79	Adjusting Plate	1	
23	794-8011-80	Pivot Pin	1	
24	794-8011-78	Adapter Plate	1	
25	794-8016-23	Stud 3/8-16 x 2.62	4	
94	000-1150-37	Flat Washer 3/8	8	
95	794-8636-60	Handle Assembly	1	
96	000-1181-33	Lock Washer 1/2	2	
97	794-8011-65	Seal	1	■
98	794-8011-66	Washer	1	■
99	000-7204-10	Roll Pin 1.20 x .625	1	■
100	794-8016-82	Handle	1	■
101	000-0485-68	Pivot Screw	2	■
102	000-1063-21	Hex Nut 5/16-24	1	■
103	000-1020-16	Hex Nut 1/4-28	2	■
104	794-8011-70	Star Dresser Assembly **	1	
	794-8644-84	(Optional) Dresser Diamond (replacement diamond only, if replacing Star Dresser then you must purchase the assembly PN: 794-8689-53)		



**Complete
Wheel Dresser Assembly**

794-8011-71

**Includes all parts marked (■) on
this page.**



Image of 794-8011-70

**** Use this part number when ordering
replacement star dresser.**



**Optional Dresser Diamond Assembly
(794-8689-53)**

FG5000/FG10000 Flywheel Grinder

ASSEMBLY DRAWING

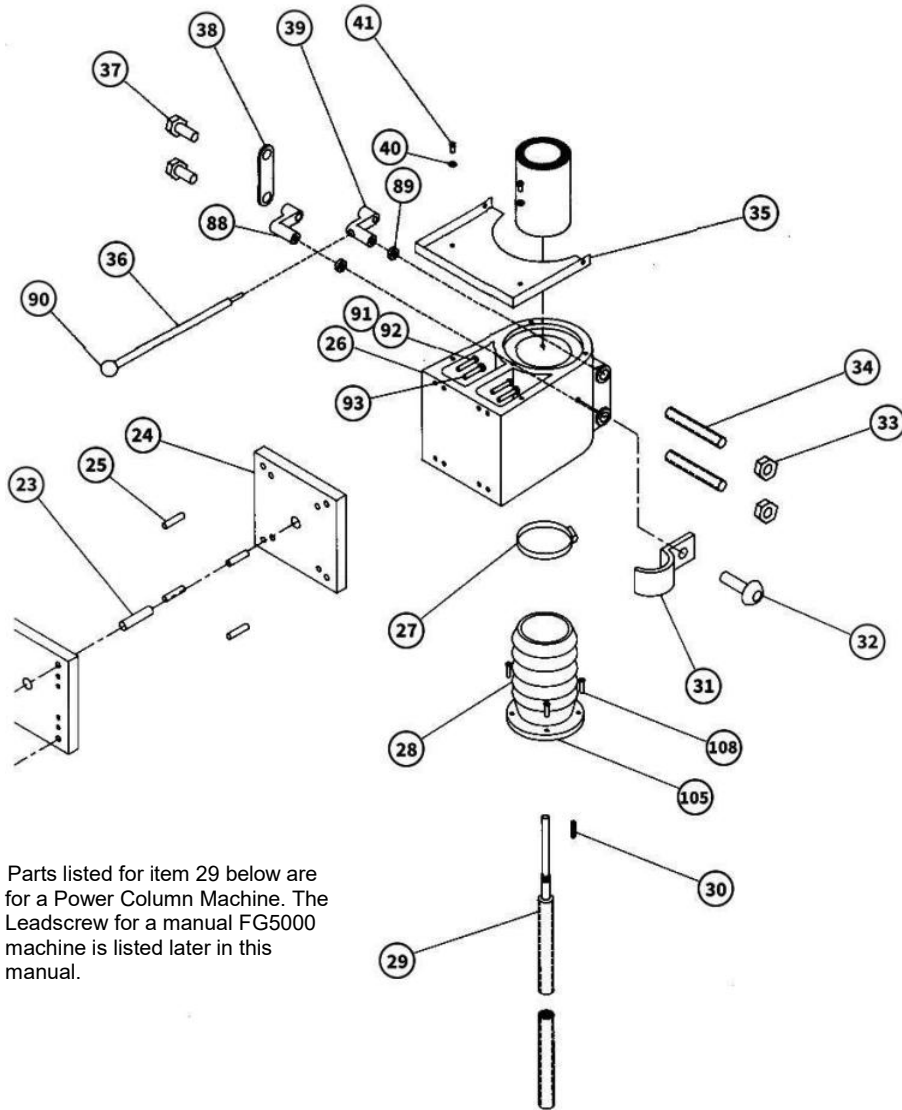

NOTE: Parts listed for item 29 below are for a Power Column Machine. The Leadscrew for a manual FG5000 machine is listed later in this manual.

ITEM	PART NO.	DESCRIPTION	QTY	ITEM	PART NO.	DESCRIPTION	QTY
23	794-8011-80	Pivot Pin	1	36	794-8011-97	Handle	2
24	794-8011-78	Adapter Plate	1	37	791-8016-42	Stripper Bolt	2
25	794-8016-23	Stud 3/8-16 x 2.62	4	38	794-8011-98	Bar	1
26	794-8687-65	Motor Flange (FG10,000)	1	39	794-8689-54	Upper Hub	1
26	794-8621-33	Motor Flange (FG5000)	1	40	000-1180-10	Lock Washer 1/4"	2
27	794-8070-88	Hose Clamp	1	41	000-0592-24	HHCS 1/4-20 x .500	2
28	794-8687-69	Column Cover (FG10,000)	1				
28	794-8012-45	Column Cover (FG5000)	1	88	794-8011-95	Lower Hub	1
29	794-8680-60	Leadscrew (FG10000)	1	89	000-1155-50	Flat Washer 1/2	1
29	794-8688-28	Leadscrew (FG5000)	1	90	800-8030-16	Ball	1
30	794-8689-40	5mm x 16mm Key ***	1	N/S	794-8680-63	Bearing	2
30	794-8689-48	3/16 SQ. X 1-3/8" Key ***	1	N/S	794-8680-62	Lock Nut	1
31	794-8688-01	Jiffy Clamp (FG10,000)	1	93	000-0170-78	SHCS 3/8-24 x 1.00	4
31	794-8143-75	Jiffy Clamp (FG5000)	1				
32	794-8016-31	BHCS 1/4-20 x .500	1				
33	000-1035-35	Hex Nut 1/2-13	2	105	794-8687-68	Retaining Flange FG10,000	1
34	794-8011-96	Column Lock Stud	2	105	794-8012-48	Retaining Flange FG5000	1
35	794-8687-30	Motor Flange Cover Plate	1	108	794-8016-07	SHCS 3/8-16 x 1.75	4

*** 794-8689-40 is for older machines. FG5 serial number 3100 and below or fg10 serial number 755 and below. 794-8689-48 is for all machines with larger serial numbers.

FG5000/FG10000 Flywheel Grinder

ASSEMBLY DRAWING

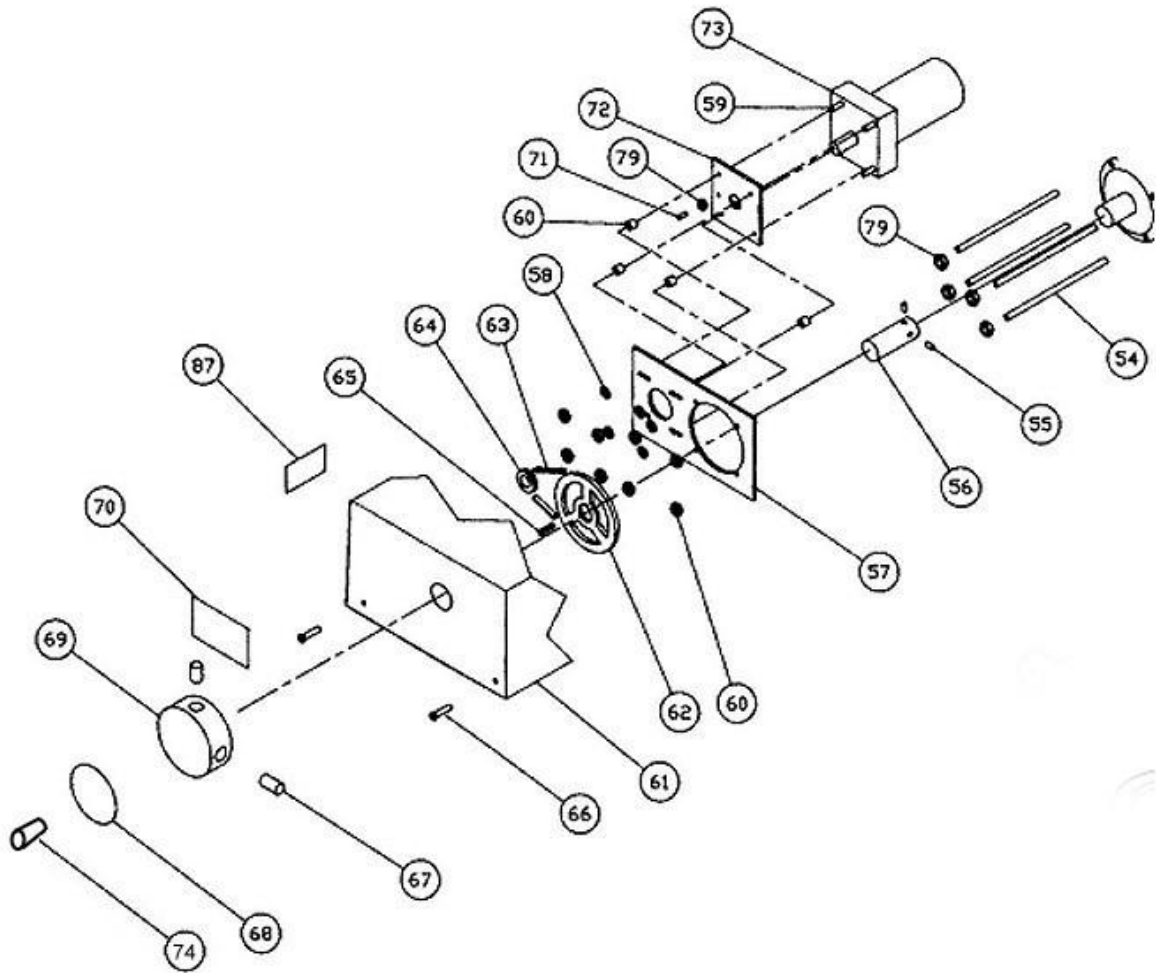

ITEM	PART NO.	DESCRIPTION	QTY	ITEM	PART NO.	DESCRIPTION	QTY
9	794-8011-63	Adjustment Collar	1	65	000-7300-41	Woodruff Key #405	1
				66	000-0595-28	BHCS #10-32 x 375	4
54	000-0206-51	8-32x5 SL Pan HD M/SCR	4	67	000-0515-00	SSS 1/4-20 x .250 Br. Tip	2
55	000-0485-10	SSS 1/4-20 x .250	2	68	794-8688-23	Label, Raise/Lower	1
56	794-8680-64	Shaft Extension	1	69	794-8687-44	Fine Feed Hand Wheel	1
57	794-8687-39	Motor Coupling Plate	1	70	794-8688-25	Label, FG10,000	1
58	000-1154-60	Washer	4	70	794-8688-24	Label, FG5000	1
59	794-8687-48	Stud #10-32 x 1.50	4	71	794-8687-52	Clutch Anchor Pin	1
60	794-8687-41	Spacer	4	72	794-8687-42	Clutch Anchor Plate	1
61	794-8687-31	Hood	1	73	794-8687-37	Auto feed Gear Motor	1
62	794-8687-45	Pulley	1	74	794-8693-53	Revolving Hand Wheel Knob	1
63	794-8687-46	Gear Belt	1	79	800-8083-74	Hex Nut #10-32 (4 no longer used for motor mount)	5
64	794-8687-38	Electromagnetic Spring Clutch	1	87	794-8688-08	Label FG5000 & FG10000	1

ASSEMBLY DRAWING

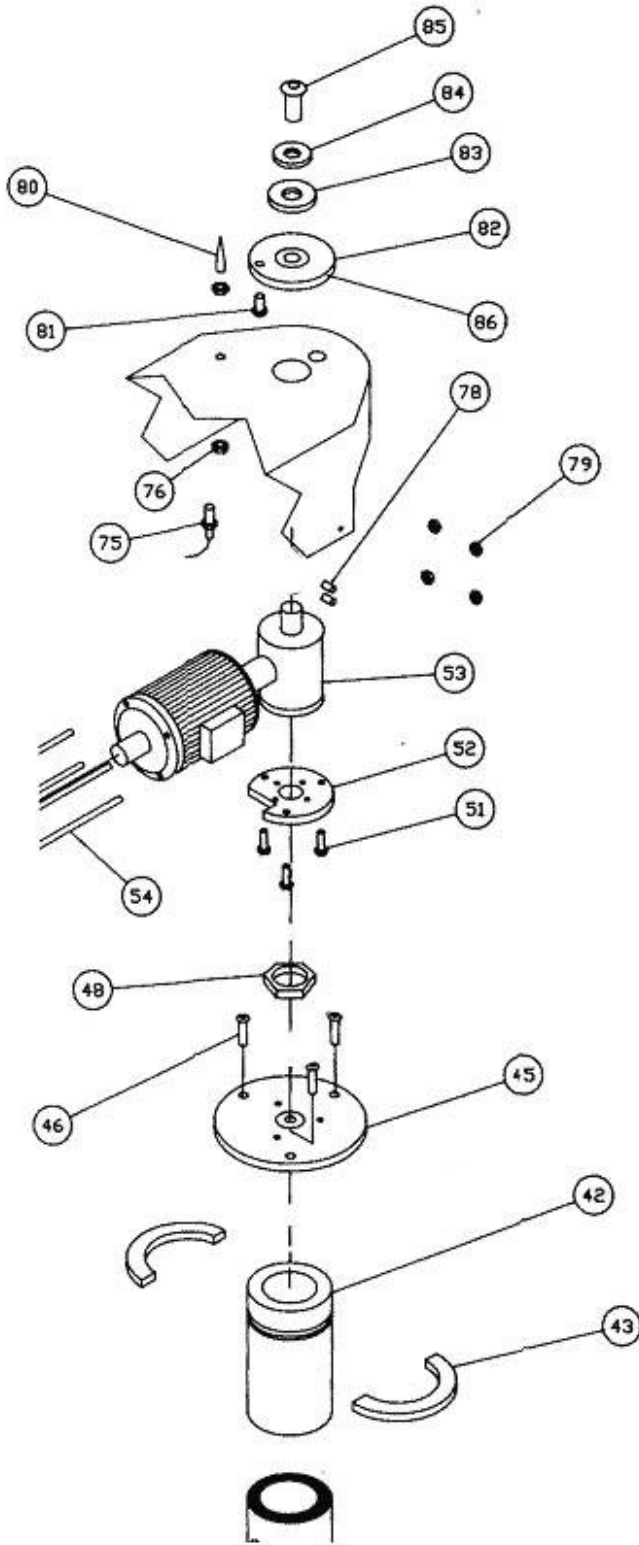

ITEM	PART #	DESCRIPTION	QTY
42	794-8687-27	Column (FG10,000)	1
42	794-8012-38	Column (FG5000)	1
43	794-8687-82	Half Ring Set (FG10,000)	1
43	794-8012-63	Half Ring Set (FG5000)	1
	794-8680-65	Column Cap (FG10,000)	1
45	794-8680-68	Column Cap (FG5000 PC/PAG)	1
	794-8012-61	Column Cap (FG5000 Manual)	1
46	000-0167-80	SHCS 5/16-18 x .75	3
46	000-0165-35	SHCS 1/4-20 x .75	3
48	794-8687-61	Bear hug Nut	1
51	794-8687-51	SHCS M6 x 14mm	4
52	794-8680-61	PC/PAG FG5000/10000 Adapter Flange	1
53	794-8680-95	Power Column Gear motor 3 Ph	1
	794-8680-96	Power Column Gear motor 1 Ph	1
75	794-8687-49	Proximity Switch	1
76	800-8083-74	Hex Nut #10-32	2
78	000-0515-00	SSS 1/4-20 x .250	2
79	800-8083-74	Hex Nut #10-32	1
80	794-8687-95	Pointer	1
81	794-8097-29	BHCS #8-32 x .250	1
82	794-8687-97	Feed Dial	1
83	794-8017-16	Spring Washer	1
84	800-8044-45	Flat Washer	1
85	000-0592-00	BHCS 5/16 x .500	1
86	794-8661-66	Label, Depth Dial	1

ASSEMBLY DRAWING

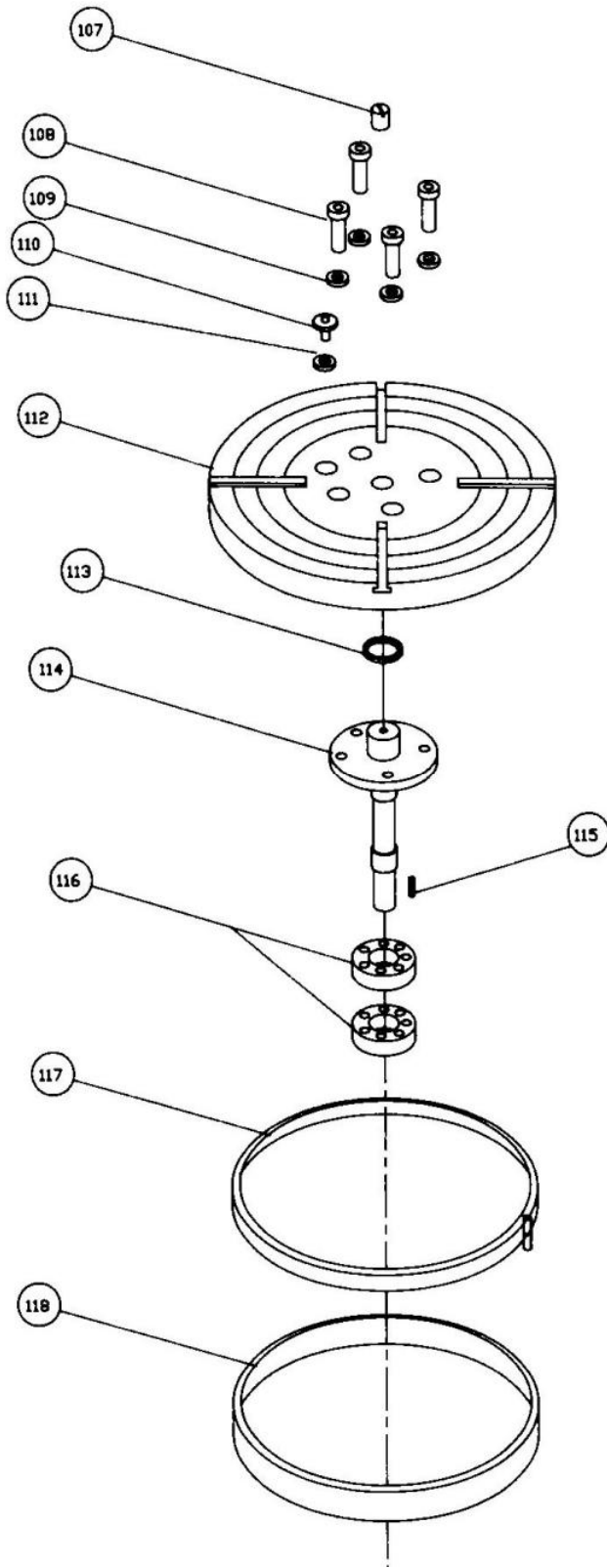

Note:
Replacement Table Spindle must be ordered using this part number.

794-8651-66
 * Includes the press-fit bearings.

ITEM	PART #	DESCRIPTION	QTY
107	794-8017-44	E-Z Lock Insert	1
108	794-8016-07	SHCS 3/8-16 x 1.75	4
109	800-8012-92	O-Ring	4
110	794-8016-54	Oil Fill Plug	1
111	794-8013-12	O-Ring	1
112	794-8012-85	Table	1
113	000-2301-38	O-Ring	1
114	794-8651-04	Table Spindle (see note above)	1
115	794-8651-06	Key	4
116	794-8012-95	Bearing	2
117	794-8012-76	Clamp	1
118	794-8012-82	Seal	1

To avoid damage to your Table Spindle (114) it is recommended that you remove the E-Z Lock Insert once a month and coat it with Anti-Seize lubricant. This prevents the insert from becoming permanently lodged in place from rust and grit.

Should the Table Spindle Threads become clogged with debris and you wish to clean them you can use a 5/8-11 tap to clean the treads.

It is not recommended to continue using a Table Spindle that has damaged threads. It is preferable to replace the Table Spindle over using a threaded insert as a repair.

TIP:
 Stuck E-Z Lock Insert Removal

E-Z Lock Inserts that become stuck in place can often be removed more easily if the Table Spindle they are in is heated. The heat loosens the insert enough to be able to coax them out. Be very careful when applying heat because of the lubricants used in and around this area. Clean all oil and other potentially flammable materials away from the area prior to applying any heat.

FG5000/FG10000 Flywheel Grinder

ASSEMBLY DRAWING

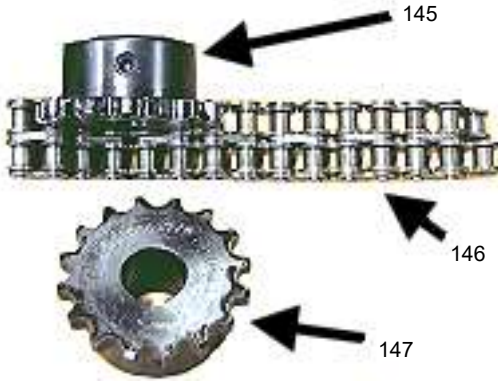
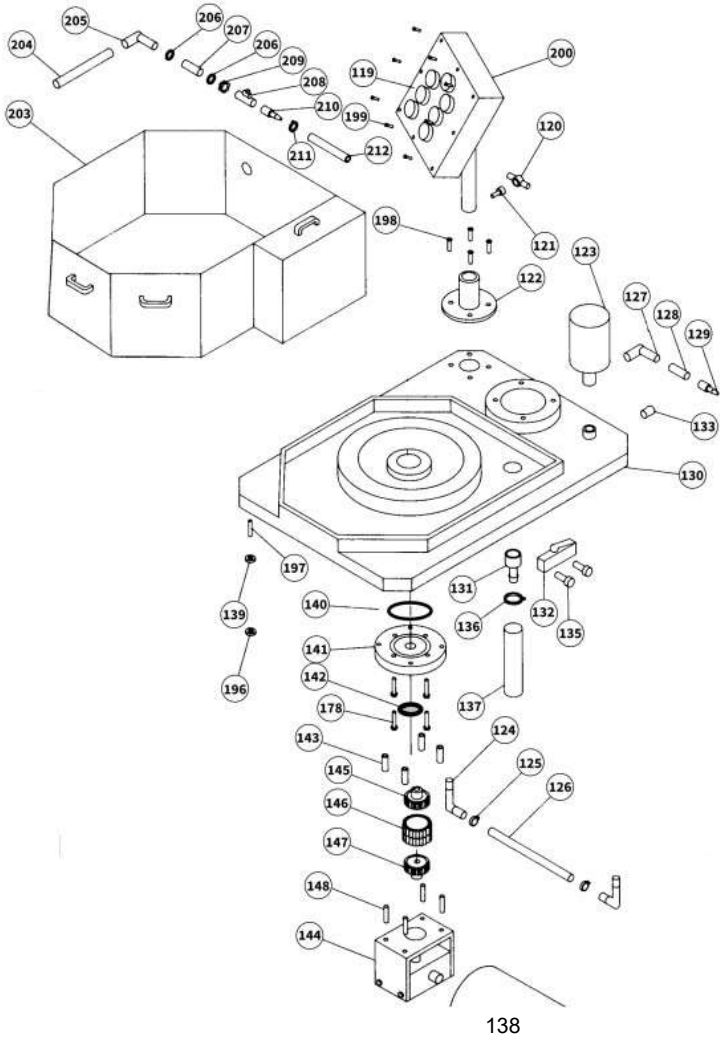

Image of items 145, 146, and 147

ITEM	PART #	DESCRIPTION	QTY
119	794-8688-17	* Control Panel Assembly (PC)	1
119	794-8687-71	* Control Panel Assembly (PCAF)	1
119	794-8689-59	* Control Panel Assembly (Man.)	1
120	800-8678-08	Knob	1
121	000-0167-80	SHCS 5/16 x .75	1
122	794-8687-96	Control Box Pivot Base	1
123	794-8013-80	Oil Reservoir	1
124	794-8044-36	Pipe Assembly	2
125	000-4200-77	Hose Clamp	1
126	794-8013-89	Tubing	1
127	000-1567-87	Elbow	1
128	794-8044-73	Tubing	1
129	000-1562-64	Fitting	1
130	794-8688-30	Base (FG5000)	1
130	794-8687-87	Base (FG10.000)	1
131	794-8690-12	Drain Hose Fitting	1
132	000-1208-50	Limit Switch	1
133	000-0485-10	SS 1/4-20 x .25	1
134	000-1180-10	Lock Washer 1/4"	4
135		Supplied with Switch	2
136	794-8690-13	Hose Clamp	1
137	794-8690-14	Drain Hose	22"
138	794-8651-08	Table Drive Motor 1/3 HP 208-230V, 50-60 Hz, 3 Ph (3 phase machine uses this motor)	1
	794-8651-09	Table Drive Motor 1/3 HP 115-230V, 60 Hz, 1 Ph (1 phase machine uses this motor)	1
139	794-8011-99	Concave Washer	2
140	794-8012-91	O-Ring	1
141	794-8651-05	Bearing Cap	1
142	794-8622-34	Seal	1
143	794-8651-15	Spacer	4
144	794-8651-07	Table Drive Gearbox	1
145	800-8651-13	Coupler	1
146	794-8651-14	Chain Coupler	1
147	794-8651-12	Coupler	1
148	794-8016-23	Stud	4
149	000-4200-77	Hose Clamp	1
196	794-8033-65	Convex Washer	2
197	794-8016-30	Stud 1/2-13 x 2.62	4
198	000-0592-24	BHCS #10-32 x .37	8
199	000-0592-28	BHCS #10-32 x .37	8
200	794-8687-29	Switch Panel Box	1
203	794-8622-47	Shroud Assembly	1
204	794-8013-13	Flex Hose w/Nozzle	1
205	794-8013-14	3/8" Pipe 45 degree Elbow	1
206	794-8013-16	Washer	2
207	794-8013-15	Nipple	1
208	794-8012-98	Valve	1
209	000-1118-28	Nut	1
210	794-8071-36	Fitting	1
211	000-4200-77	Clamp	1
212	794-8071-18	Hose	1

* All buttons assembled onto the panel and wired together with the common wire. Ready to be mounted in the control box.

FG5000/FG10000 Flywheel Grinder

ASSEMBLY DRAWING

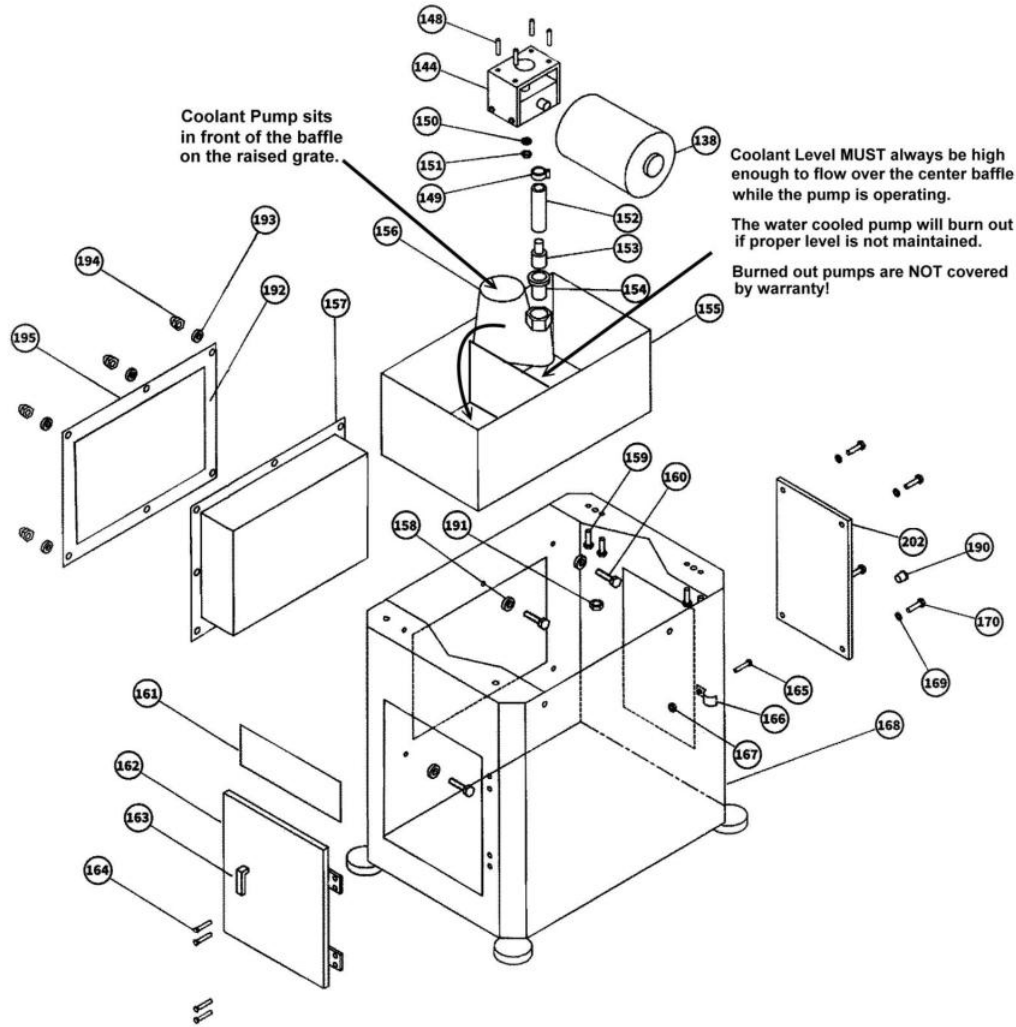

ITEM	PART #	DESCRIPTION	QTY	ITEM	PART #	DESCRIPTION	QTY
138	794-8651-08	1/3 HP Table Motor - 208-230V, 50-60 Hz, 3 Ph	1	161	000-6601-28	Van Norman Label	1
	794-8651-09	1/3 HP Table Motor - 115-230V, 60 Hz, 1 Ph	1	162	794-8082-75	Front Door w/Hinges**	1
	794-8692-81	Pump Stand-Off Grate (not shown)	1	163	800-8017-23	Door Latch	1
144	794-8651-07	Table Drive Gearbox	1	164	000-0205-75	Screw #10-32 x .25	4
				165	000-0592-24	BHCS 1/4-20 x .50	1
148	794-8016-23	Stud	4	166	794-8688-01	Jiffy Clamp 3/4" FG10,000	1
149	000-4200-77	Hose Clamp	1	166	794-8143-75	Jiffy Clamp 1/2" FG5000	1
150	800-8030-61	Lock Washer 3/8	4	167	000-1020-08	Hex Nut 1/4-20	1
151	000-1035-19	Hex Nut 3/8	4	168	794-8687-89	Base Cabinet	1
152	794-8619-33	Coolant Hose	1	169	000-1180-10	Lock Washer	4
153	003-0005-70	Fitting	1	170	000-0100-30	HHCS 1/4-20 x .75	4
154	794-8621-71	Reducer Bushing	1				
155	794-8620-47	Coolant Tank	1	190	794-8687-93	Power Cable Bushing	1
156	794-8671-15	Coolant Pump 230V, 50 Hz, 1Ph	1	191	000-1140-30	Hex Nut 1/2-13	4
156	794-8621-76	Coolant Pump 115V, 60 Hz, 1 Ph	1	192	800-8062-30	Weather-strip	80"
157	794-8687-77	Starter Box	1	193	000-1150-10	Flat Washer 1/4"	6
158	000-1180-10	Lock Washer 1/4"	6	194	794-8062-35	Acorn Nut 1/4"	6
159	000-0105-53	HHCS 3/8-16 x 1.25	4	195	794-8687-94	Cover Panel	1
160	000-0100-30	HHCS 1/4-20 x .75	6	202	794-8620-12	Rear Cover Panel	1

** Front Door Hinges are not sold separately from the door panel

FG5000/FG10000 Flywheel Grinder

ASSEMBLY DRAWING

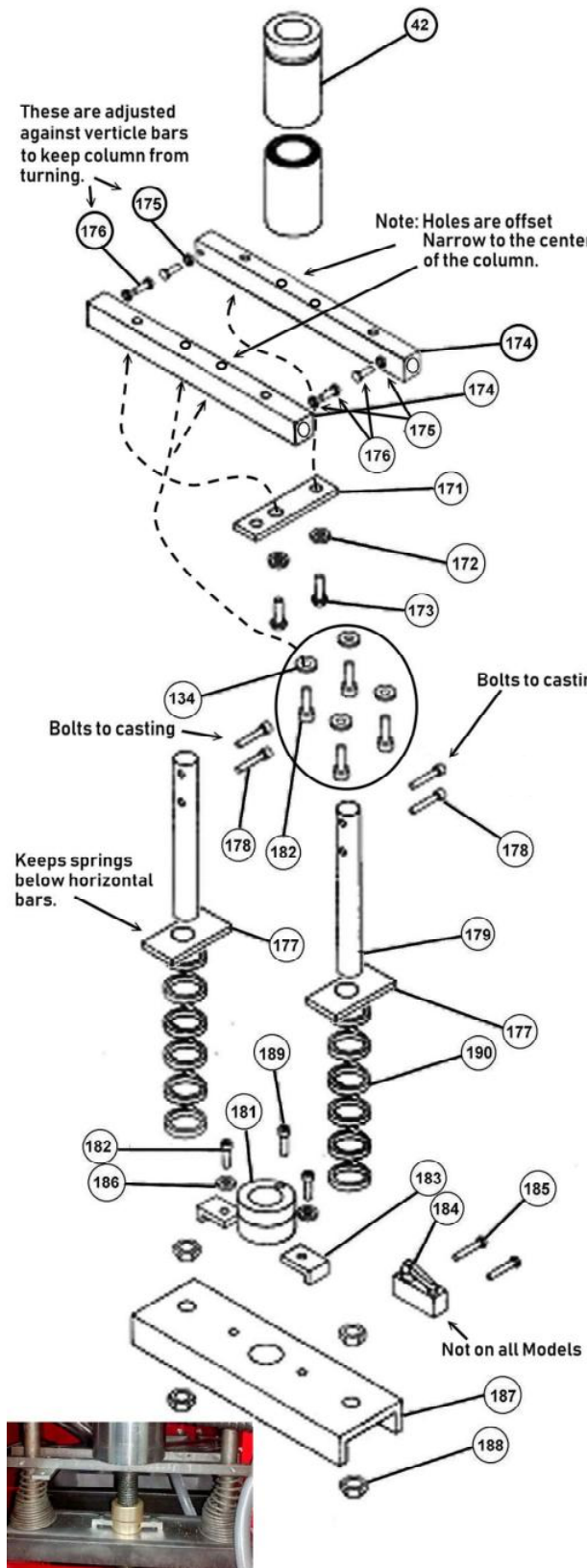

ITEM	PART #	DESCRIPTION	QTY
42	794-8687-27	Column (FG10,000)	1
	794-8012-38	Column (FG5000)	1
171	794-8012-54	Plate	1
172	000-1180-10	Lock Washer	2
174	794-8687-86	Bar, Channel Support	2
173	000-0100-30	HHCS 1/4-20 x .75	2
175	000-1020-08	HHCS 1/4-20 x .75	5
176	000-1020-08	Hex Nut 1/4-20	3
177	794-8012-26	Plate	2
178	000-0170-35	SHCS 3/8-16 x 1.25	8
179	794-8687-81	Support Bar (FG10,000)	2
	794-8012-23	Support Bar (FG5000)	2
180	794-8012-29	Column Support Spring 14.0	2
181	794-8012-34	Leadscrew Nut for FG5000 with Serial No. 3283 and up	1
	794-8012-34	Leadscrew Nut for FG10000 with Serial No. 795 and up	1
	794-8012-36	Leadscrew Nut for FG5000 with Serial No. 3282 and below	1
	794-8012-36	Leadscrew Nut for FG10000 with Serial No. 794 and below	1
** See Below			
183	794-8012-32	Leadscrew Nut Clamp	2
182	000-0166-08	SHCS 1/4-20 x 1.00	3
184	000-1208-50	Limit Switch	1
185		(Supplied with Switch, Item 184)	2
186	000-1180-10	Lock Washer 1/4"	2
187	794-8012-24	Lower Support (FG5,000)	1
187	794-8687-64	Lower Support (FG10,000)	1
188	794-8044-75	Hex Nut 1.00-14	4
189	794-8016-33	SSCS #10-24 x 1.50	1

NOTE: Basic steps to change the Leadscrew Nut.

1. Move column to top position
2. Use cribbing to support column
3. Lower column onto cribbing
4. Remove items 182 from items 183
5. Remove item 188 hex nuts being careful to support bar 187 as it has slight spring tension downward
6. Slide item 187 down off of Leadscrew
7. Turn Leadscrew Nut item 181 off of Leadscrew
8. Reverse this process with new replacement Leadscrew Nut.

IF YOU NEED ADDITIONAL HELP PLEASE CONTACT IRONTITE SUPPORT

** These Leadscrew Nut part numbers are for backward compatibility with an existing Leadscrew. IF you are purchasing a NEW Leadscrew then you must purchase the 794-8012-34 (new version) Leadscrew Nut.

FG5000/FG10000 Flywheel Grinder

ASSEMBLY DRAWING

ITEM	PART #	DESCRIPTION	QTY
44	794-8012-51	Bearing	1
45	794-8680-65	Column Cap (FG10,000)	1
	794-8012-61	Column Cap (FG5000 Manual)	1
	794-8680-68	Column Cap (FG5000 PC/PAG)	1
47	000-1605-39	Bearing	1
119	794-8688-17	* Control Panel Assembly (PC)	1
119	794-8687-71	* Control Panel Assembly (PCAF)	1
119	794-8689-59	* Control Panel Assembly (Man.)	1
120	800-8678-08	Knob	1
121	000-0167-80	SHCS 5/16 x .75	1
122	794-8687-96	Control Box Pivot Base	1
200	794-8687-29	Switch Panel Box	1
203	794-8622-47	Shroud Assembly	1
204	794-8013-13	Flex Hose w/Nozzle	1
205	794-8013-14	3/8" Pipe 45 degree Elbow	1
206	794-8013-16	Washer	2
207	794-8013-15	Nipple	1
208	794-8012-98	Valve	1
209	000-1118-28	Nut	1
210	794-8071-36	Fitting	1
211	000-4200-77	Clamp	1
212	794-8071-18	Hose	1
213	800-8031-25	Nut .62-11	1
214	794-8015-62	Star Washer	1
215	794-8012-40	Hand wheel	1
216	794-8012-44	Spacer	1
217	800-8663-77	Washer	2
218	794-8688-09	Dial, Graduated	1
219 (See Note)	794-8688-27	Leadscrew (FG5 SN: 3100 & below)	1
	794-8688-28	Leadscrew (FG5 SN: 3101 & above)	1
	794-8687-60	Leadscrew (FG10 SN: 755 & below)	1
	794-8680-60	Leadscrew (FG10 SN: 756 & above)	1
	794-8012-35	Leadscrew (Manual Mach)	1
220	794-8017-16	Spring Washer	1
221	800-8012-68	Pointer	1
222	804-8017-17	Key, Woodruff	1

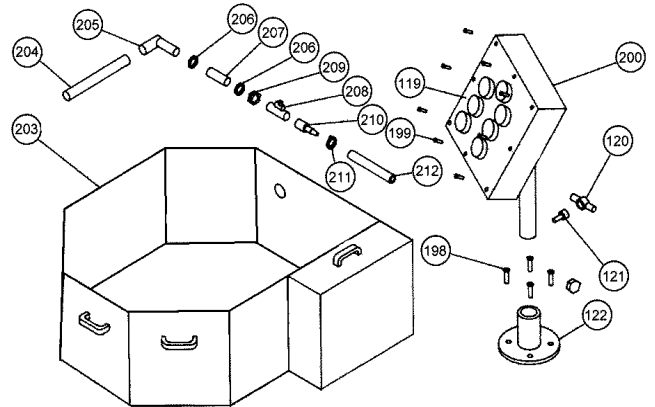

MANUAL LEADSCREW ASSEMBLY

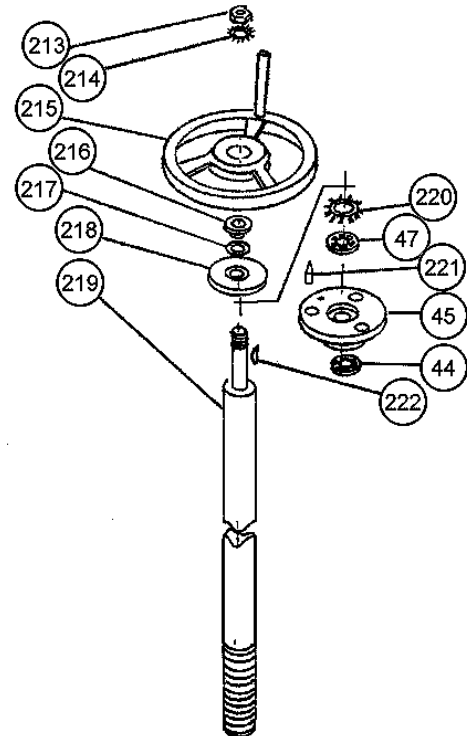

* All buttons assembled onto the panel and wired together with the common wire. Ready to be mounted in the control box.

Note: Older Machines had a silver colored column gear motor while newer machines all have a black colored column gear motor.

- FG5000 Non-Manual machines with Serial Number 3100 or lower use 794-8688-27 (Leadscrew) & 794-8012-34 (Leadscrew nut)
- FG10000 Non-Manual machines with Serial Number 755 or lower use 794-8687-60 (Leadscrew) & 794-8012-34 (Leadscrew nut)

When you purchase a new Leadscrew you MUST also purchase a new Leadscrew Nut.

ELECTRICALS & WIRING By Machine Model

SWITCH PANEL ASSEMBLY

MACHINE MODEL NUMBERS:

794-8690-00
794-8690-01
794-8690-02
794-8690-03
794-8690-08

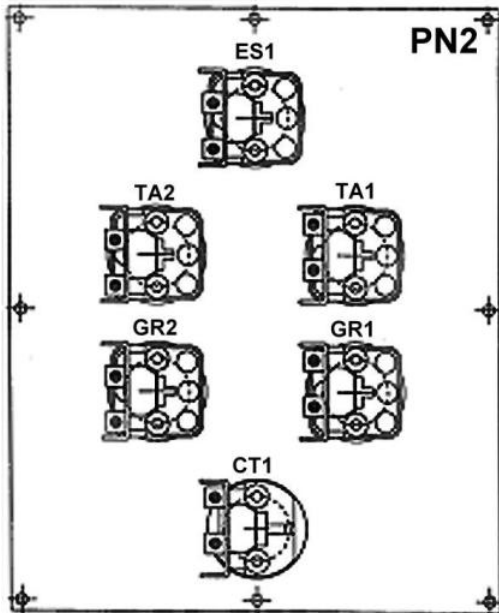

ITEM	PART #	DESCRIPTION
PN2	794-8688-16	Switch Panel
ES1	794-8623-14	Emergency Stop Switch
TA2	794-8622-82	Table Stop (Red)
TA1	794-8622-81	Table Start (Green)
GR2	794-8622-82	Grinder Stop (Red)
GR1	794-8622-81	Grinder Start (Green)
CT1	794-8622-83	Coolant Switch

SWITCH PANEL ASSEMBLY

MACHINE MODEL NUMBERS:

794-8688-22
794-8688-35
794-8688-36
794-8688-40
794-8688-41
794-8688-42
794-8688-43

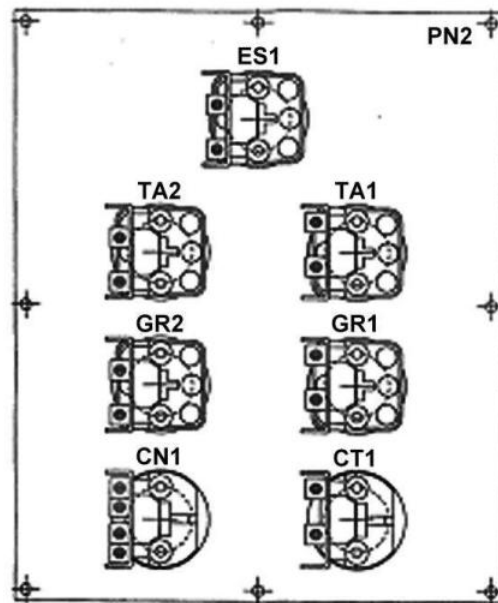

ITEM	PART #	DESCRIPTION
PN2	794-8688-16	Switch Panel
ES1	794-8623-14	Emergency Stop Switch
TA2	794-8622-82	Table Stop (Red)
TA1	794-8622-81	Table Start (Green)
GR2	794-8622-82	Grinder Stop (Red)
GR1	794-8622-81	Grinder Start (Green)
CN1	794-8625-14	Power Column Switch
CT1	794-8622-83	Coolant Switch

Optional Heavy Duty Switches

TA2, GR2 794-8622-85 HD RED Push Button
TA1, GR1 794-8622-84 HD GREEN Push Button

Note: The Power Column Switch can be re-oriented by moving the lock-ring to make the white line point in the correct direction.

SWITCH PANEL ASSEMBLY (cont.)

MACHINE MODEL NUMBERS:

794-8688-22, 794-8688-35, 794-8688-36, 794-8688-40,
794-8688-41, 794-8688-42, 794-8688-43

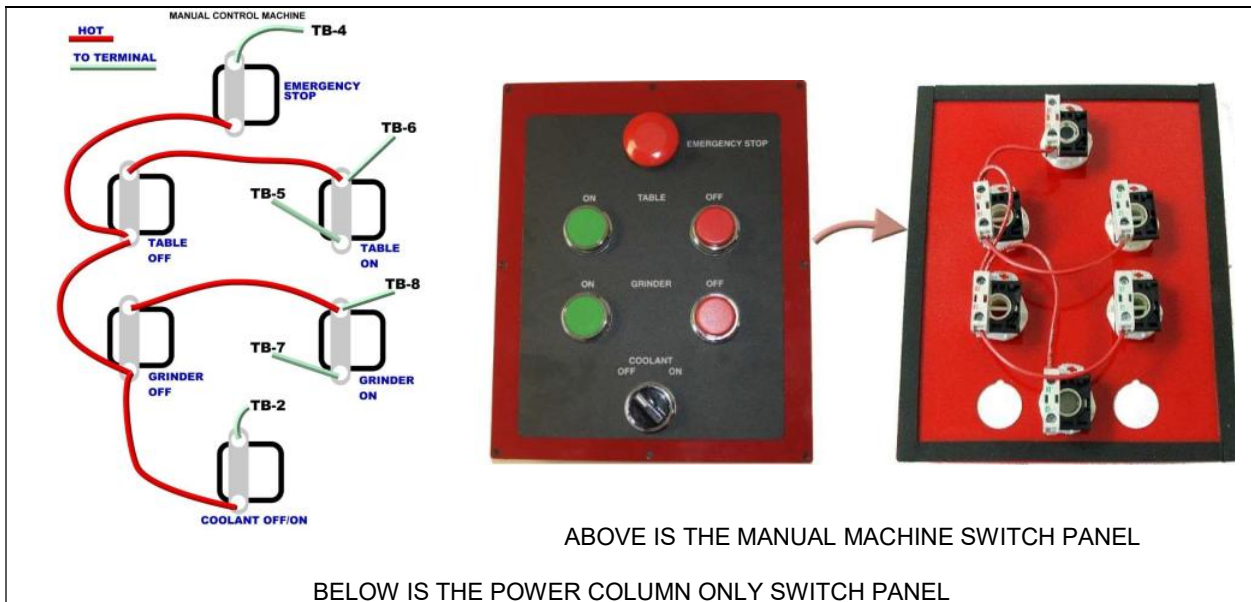

POWER COLUMN SWITCH

NOTE: The power column switch is actually 2 switches in one. The jumper wire connects one side of both of these two switches. It connects to contacts that are further apart. See this same image for the Auto-Grind machine to see a photo of the switch and how it's connected if you are unsure. If you connect this wrong you will cause further damage to your machine.

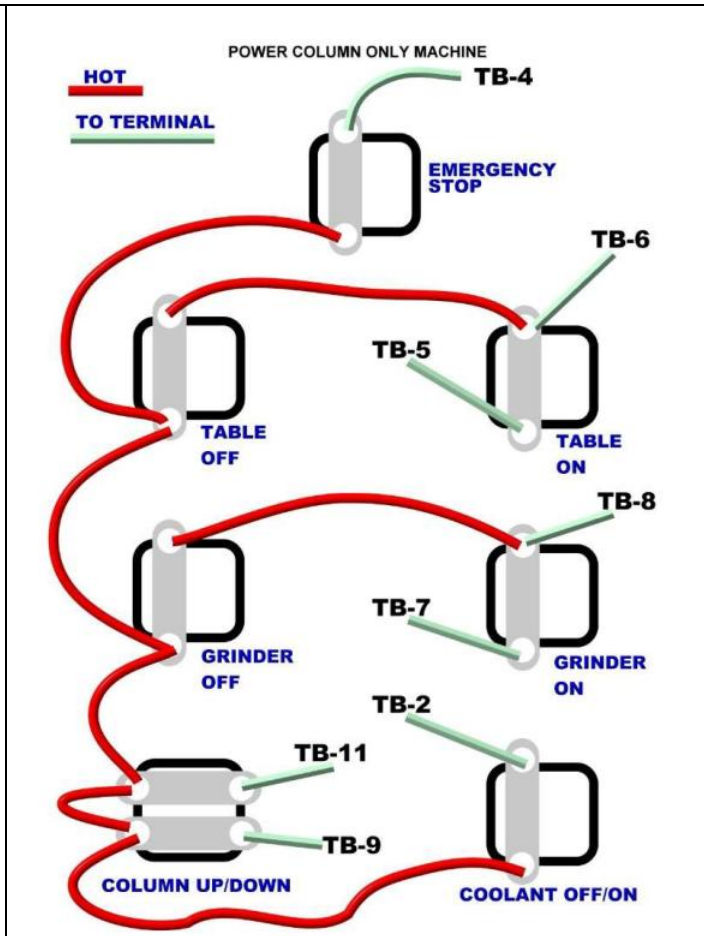

SWITCH PANEL ASSEMBLY

MACHINE MODEL NUMBERS:

- 794-8688-06
- 794-8688-37
- 794-8688-38
- 794-8688-50
- 794-8688-51
- 794-8688-52
- 794-8688-53

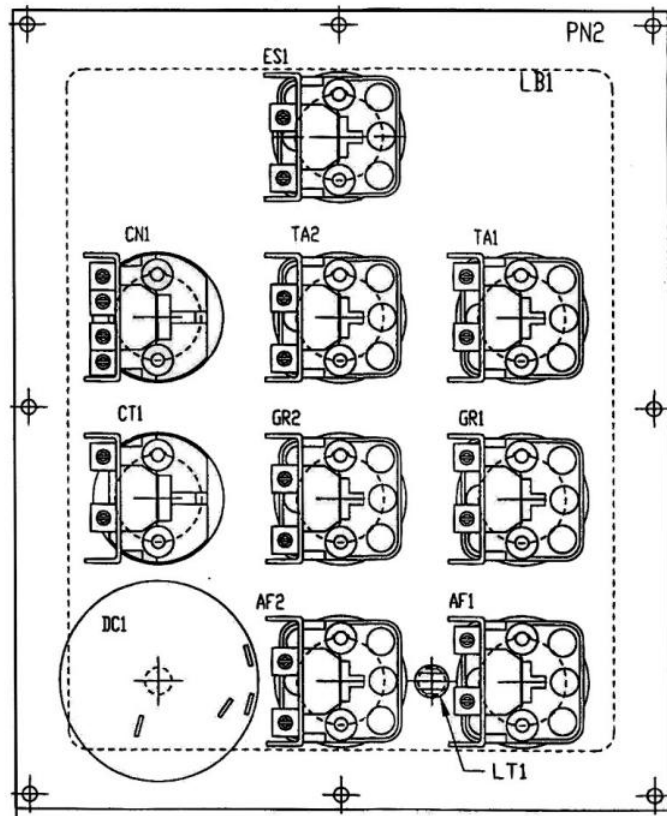

ITEM	PART #	HD Version	DESCRIPTION
PN2	794-8687-28		Switch Panel
ES1	794-8623-14		Emergency Stop Switch
TA2	794-8622-82	794-8622-85	Table Stop (Red)
TA1	794-8622-81	794-8622-84	Table Start (Green)
GR2	794-8622-82	794-8622-85	Grinder Stop (Red)
GR1	794-8622-81	794-8622-84	Grinder Start (Green)
CN1	794-8625-14		Power Column Switch
CT1	794-8622-83		Coolant Switch
DC1	001-1915-40		D.C. Controller
AF2	794-8622-82	794-8622-85	Auto Feed Stop (Red)
AF1	794-8622-81	794-8622-84	Auto Feed Start (Green)
LT1	794-8687-70		Light

Note: The Power Column Switch can be re-oriented by moving the lock-ring to make the white line point in the correct direction.

SWITCH PANEL ASSEMBLY – cont.

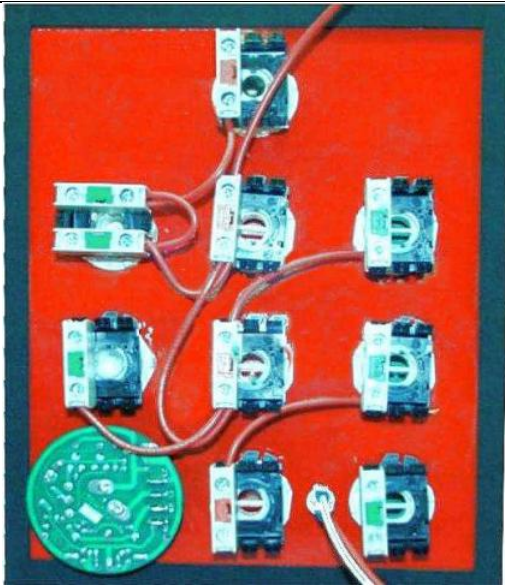

Photo of Common Wired Back Side

MACHINE MODEL NUMBERS:

- 794-8688-06 -- FG10000 208-230/60/3 PAG
- 794-8688-37 -- FG10000 380/50/3 PAG
- 794-8688-38 -- FG10000 460/60/3 PAG
- 794-8688-50 -- FG5000 208-230/60/3 PAG
- 794-8688-51 -- FG5000 208-230/60/1 PAG
- 794-8688-52 -- FG5000 380/50/3 PAG
- 794-8688-53 -- FG5000 460/60/3 PAG

POWER COLUMN SWITCH

NOTE: Incorrect wiring will cause additional damage to your machine. If you are not sure use a volt meter and be sure before you apply power.

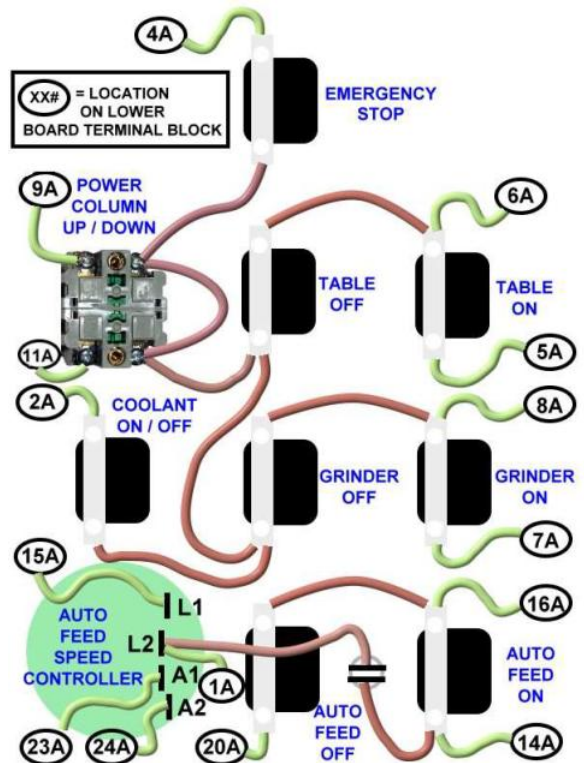

Wiring Diagram for back side of Control Panel.

CONTROL BOX ASSEMBLY

MACHINE MODEL NUMBERS / VOLTS / HZ / PHASE

794-8690-00 -- FG5000 208-230/60/3
794-8690-02 -- FG5000 460/60/3
794-8690-08 -- FG5000 460/50-60/3

794-8690-00		794-8690-02 & 08		DESCRIPTION	794-8690-00		794-8690-02 & 08		DESCRIPTION
ITEM	PART #	PART #	PART #		ITEM	PART #	PART #	PART #	
BX1	794-8687-77	794-8687-77		Control Box	TF1	794-8676-78	794-8623-17	Transformer	
PN1	794-8687-78	794-8687-78		Panel	TB1	794-8622-44	794-8622-44	Terminal Barrier	
DR1	794-8014-10	794-8014-10		Din Rail	SR1	794-8687-79	794-8687-79	Strain Relief	
MR1	794-8691-46	794-8691-46		Motor Relay	SR2	794-8144-03	794-8144-03	Strain Relief	
MD1	794-8691-63	794-8691-63		Motor Overload	SR3	800-8014-71	800-8014-71	Strain Relief	
MR2	794-8691-45	794-8691-45		Motor Relay	SR4	800-8014-71	800-8014-71	Strain Relief	
MD2	794-8691-57	794-8691-57		Motor Overload	SR5	800-8014-71	800-8014-71	Strain Relief	
GND	794-8142-14	794-8142-14		Ground Lug	SR6	800-8014-71	800-8014-71	Strain Relief	
FB1	794-8132-70	794-8132-70		Fuse Holder	SR7	800-8014-71	800-8014-71	Strain Relief	
F1	794-8132-69	794-8132-69		Fuse	SRN3	800-8667-93	800-8667-93	Strain Relief Nut	
F2	794-8132-69	794-8132-69		Fuse	SRN4	800-8667-93	800-8667-93	Strain Relief Nut	
F3	794-8132-69	794-8132-69		Fuse	SRN5	800-8667-93	800-8667-93	Strain Relief Nut	
F4	794-8119-78	794-8119-78		Fuse	SRN6	800-8667-93	800-8667-93	Strain Relief Nut	
FB4	794-8142-66	794-8142-66		Fuse Holder	SRN7	800-8667-93	800-8667-93	Strain Relief Nut	
FX1	794-142-117	794-142-117		Fuse					

*460v machines have the second GND near the terminal strip for CSA compliance

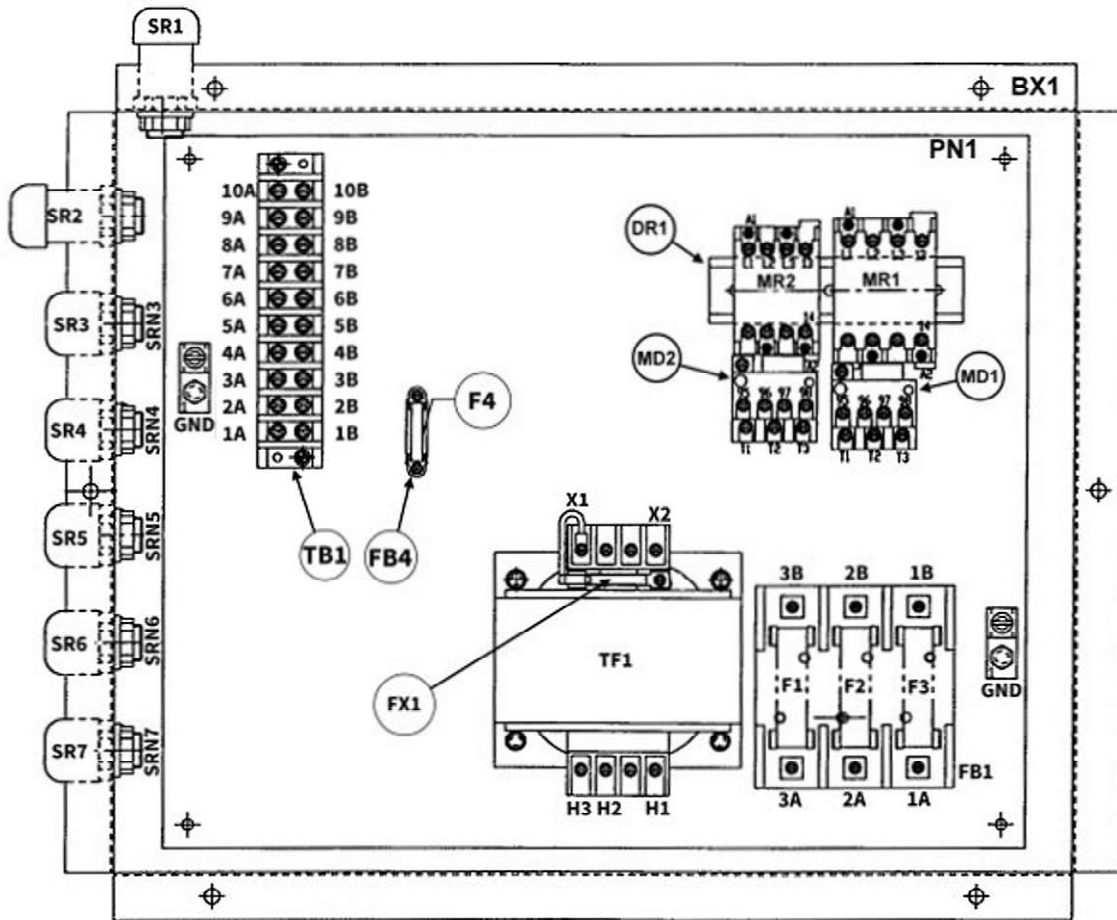

CONTROL BOX ASSEMBLY
MACHINE MODEL NUMBERS / VOLTS / HZ / PHASE

794-8690-01 -- FG5000 230/60/1

ITEM	PART #	DESCRIPTION
BX1	794-8687-77	Control Box
PN1	794-8687-78	Panel
DR1	794-8014-10	Din Rail
GND	794-8142-14	Ground Lug
FB1	794-8624-11	Fuse Holder
F1	794-8633-68	Fuse
F2	794-8142-66	Fuse
FB3	794-1421-19	Fuse Holder
F3	794-8691-47	Fuse
TF1	794-8677-74	Transformer
MR1	794-8691-56	Motor Relay
MD1	794-8691-45	Motor Overload
MR2	794-8691-58	Motor Relay
MD2	794-8622-44	Motor Overload
TB1	794-8687-79	Terminal Barrier
SR1	794-8144-03	Strain Relief
SR2	800-8014-71	Strain Relief
SR3	800-8014-71	Strain Relief
SR4	800-8014-71	Strain Relief
SR5	800-8014-71	Strain Relief
SR6	800-8014-71	Strain Relief
SR7	800-8014-71	Strain Relief
SRN3	800-8667-93	Strain Relief Nut
SRN4	800-8667-93	Strain Relief Nut
SRN5	800-8667-93	Strain Relief Nut
SRN6	800-8667-93	Strain Relief Nut
SRN7	800-8667-93	Strain Relief Nut

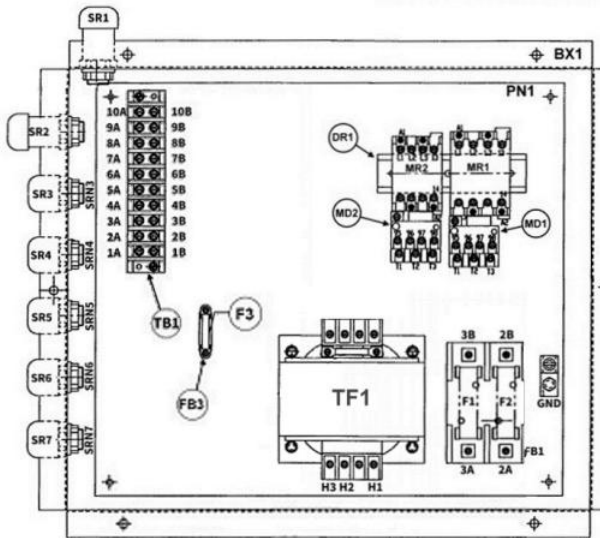

794-8690-03 -- FG5000 380/50/3

ITEM	PART #	DESCRIPTION
BX1	794-8687-77	Control Box
PN1	794-8687-78	Panel
DR1	794-8014-10	Din Rail
MR1	794-8691-46	Motor Relay
MD1	794-8691-51	Motor Overload
MR2	794-8691-45	Motor Relay
MD2	794-8691-59	Motor Overload
GND	794-8142-14	Ground Lug
FB1	794-8180-16	Fuse Holder
F1	794-8659-98	Fuse
F2	794-8659-98	Fuse
F3	794-8659-98	Fuse
FX1	794-8119-78	Fuse
TF1	794-8677-74	Transformer
FB4	794-8142-66	Fuse Holder
F4	794-8119-78	Fuse
TB1	794-8626-01	Terminal Barrier
SR1	794-8687-79	Strain Relief
SR2	794-8144-03	Strain Relief
SR3	800-8014-71	Strain Relief
SR4	800-8014-71	Strain Relief
SR5	800-8014-71	Strain Relief
SR6	800-8014-71	Strain Relief
SR7	800-8014-71	Strain Relief
SRN3	800-8667-93	Strain Relief Nut
SRN4	800-8667-93	Strain Relief Nut
SRN5	800-8667-93	Strain Relief Nut
SRN6	800-8667-93	Strain Relief Nut
SRN7	800-8667-93	Strain Relief Nut

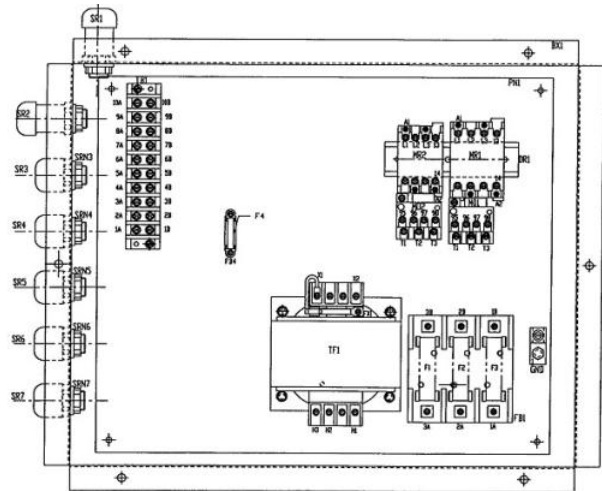

(Image is the same as Layout 1 on the previous page)

CONTROL BOX ASSEMBLY MACHINE MODEL NUMBERS

- 794-8688-22 - FG10000 208-230/60/3 PC
- 794-8688-36 - FG10000 460/60/3 PC
- 794-8688-40 - FG5000 208-230/60/3 PC
- 794-8688-43 - FG5000 460/60/3 PC

ITEM	794-8688-22 PART #	794-8688-36 PART #	794-8688-40 PART #	794-8688-43 PART #	DESCRIPTION
BX1	794-8687-77	794-8687-77	794-8687-77	794-8687-77	Control Box
PN1	794-8687-78	794-8687-78	794-8687-78	794-8687-78	Panel
DR1	794-8687-72	794-8687-72	794-8687-72	794-8687-72	Din Rail
*GND	794-8142-14	794-8142-14	794-8142-14	794-8142-14	Ground Lug
FB1	794-8686-75	794-8180-16	794-8132-70	794-8180-16	Fuse Holder
F1	794-8633-68	794-8688-72	794-8132-69	794-8659-98	Fuse
F2	794-8633-68	794-8688-72	794-8132-69	794-8659-98	Fuse
F3	794-8633-68	794-8688-72	794-8132-69	794-8659-98	Fuse
TF1	794-8676-78	794-8623-17	794-8676-78	794-8623-17	Transformer
FX1	794-1421-17	794-1421-17	794-1421-17	794-1421-17	Fuse
MR1	794-8691-47	794-8691-46	794-8691-46	794-8691-46	Motor Relay
MD1	794-8691-55	794-8691-55	794-8691-63	794-8691-51	Motor Overload
MR2	794-8691-45	794-8691-45	794-8691-45	794-8691-45	Motor Relay
MD2	794-8691-57	794-8691-57	794-8691-57	794-8691-59	Motor Overload
TB1	794-8626-01	794-8626-01	794-8626-01	794-8626-01	Terminal Barrier
CR1	794-8625-15	794-8625-15	794-8625-15	794-8625-15	Relay
CR2	794-8625-15	794-8625-15	794-8625-15	794-8625-15	Relay
CR3	794-8625-15	794-8625-15	794-8625-15	794-8625-15	Relay
SR1	794-8687-79	794-8687-79	794-8687-79	794-8687-79	Strain Relief
SR2	794-8687-79	794-8144-03	794-8144-03	794-8144-03	Strain Relief
SR3	800-8014-69	800-8014-69	800-8014-69	800-8014-71	Strain Relief
SR4	800-8014-69	800-8014-69	800-8014-69	800-8014-71	Strain Relief
SR5	800-8014-69	800-8014-69	800-8014-69	800-8014-71	Strain Relief
SR6	800-8014-69	800-8014-69	800-8014-69	800-8014-71	Strain Relief
SR7	800-8014-71	800-8014-71	800-8014-71	800-8014-71	Strain Relief
SRN3	800-8667-93	800-8667-93	800-8667-93	800-8667-93	Strain Relief Nut
SRN4	800-8667-93	800-8667-93	800-8667-93	800-8667-93	Strain Relief Nut
SRN5	800-8667-93	800-8667-93	800-8667-93	800-8667-93	Strain Relief Nut
SRN6	800-8667-93	800-8667-93	800-8667-93	800-8667-93	Strain Relief Nut
SRN7	800-8667-93	800-8667-93	800-8667-93	800-8667-93	Strain Relief Nut
PCTB	794-8016-71	794-8016-71	794-8016-71	794-8016-71	Printed Circuit Board

*460v machines have the second GND near the terminal strip for CSA compliance

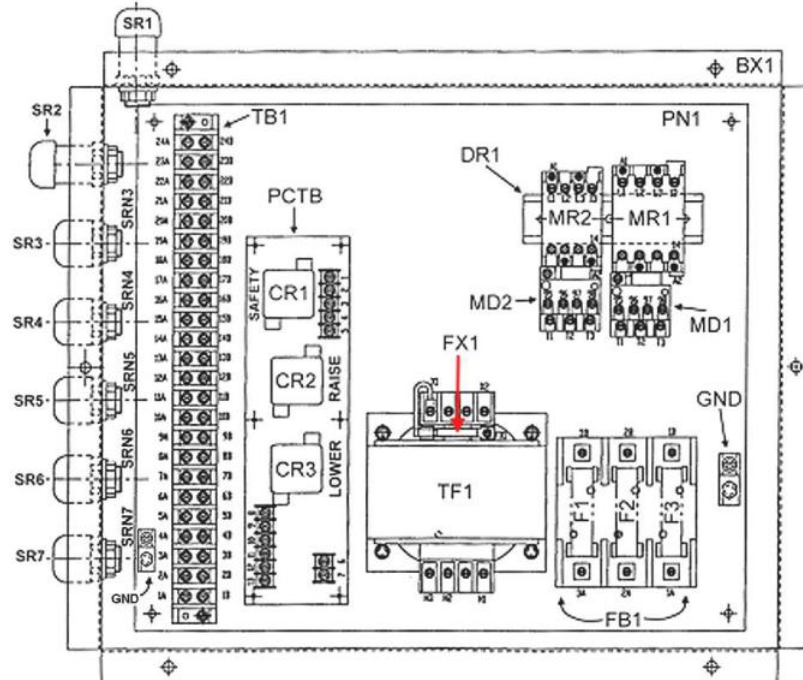

CONTROL BOX ASSEMBLY
MACHINE MODEL NUMBERS / VOLTS / HZ / PHASE

794-8688-41 -- FG5000 208-230/60/1 PC

ITEM	PART #	DESCRIPTION
BX1	794-8687-77	Control Box
PN2	794-8687-78	Panel
DR1	794-8687-72	Din Rail
GND	794-8142-14	Ground Lug
FB1	794-8624-11	Fuse Holder
F1	794-8633-68	Fuse
F2	794-8633-68	Fuse
F3	794-1421-17	Fuse
F4	794-1421-17	Fuse
MR1	794-8691-47	Motor Relay
MD1	794-8691-56	Motor Overload
MR2	794-8691-45	Motor Relay
MD2	794-8691-58	Motor Overload
RS1	794-8687-73	Relay Socket
RS2	794-8687-73	Relay Socket
TB1	794-8626-01	Terminal Barrier
CR1	794-8625-15	Relay
CR2	794-8625-15	Relay
FB3	794-8142-66	Fuse Holder
FB4	794-8142-66	Fuse Holder
SR1	794-8687-79	Strain Relief
SR2	794-9144-03	Strain Relief
SR3	794-8144-03	Strain Relief
SR4	800-8014-71	Strain Relief
SR5	800-8014-71	Strain Relief
SR6	800-8014-71	Strain Relief
SR7	800-8014-71	Strain Relief
SRN3	800-8667-93	Strain Relief Nut
SRN4	800-8667-93	Strain Relief Nut
SRN5	800-8667-93	Strain Relief Nut
SRN6	800-8667-93	Strain Relief Nut
SRN7	800-8667-93	Strain Relief Nut
AC1	794-8688-93	Auxiliary Control
DR2	794-8014-10	Din Rail

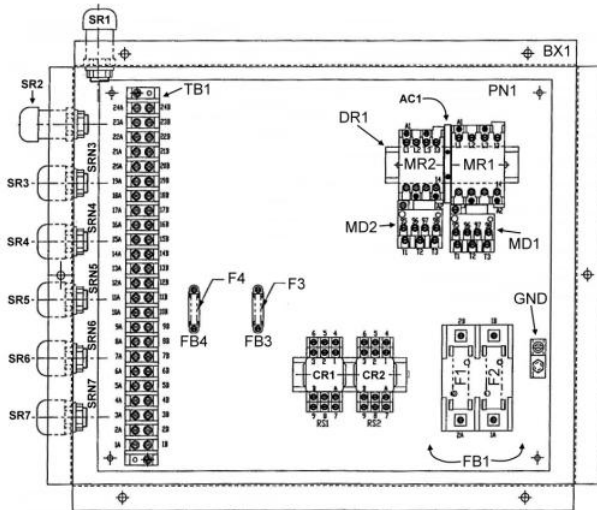

794-8688-35 -- FG10000 380/50/3
794-8688-42 -- FG5000 380/50/3 PC

ITEM	PART #	PART #	DESCRIPTION
BX1	794-8687-77	794-8687-77	Control Box
PN1	794-8687-78	794-8687-78	Panel
DR1	794-8687-72	794-8687-72	Din Rail
GND	794-8142-14	794-8142-14	Ground Lug
FB1	794-8180-16	794-8180-16	Fuse Holder
F1	794-8688-72	794-8659-98	Fuse
F2	794-8688-72	794-8659-98	Fuse
F3	794-8688-72	794-8659-98	Fuse
TF1	794-8677-74	794-8677-74	Transformer
MX1	794-8119-78	794-8119-78	Fuse
MR1	794-8691-46	794-8691-46	Motor Relay
MO1	794-8691-63	794-8691-51	Motor Overload
MR2	794-8691-45	794-8691-45	Motor Relay
MO2	794-8691-59	794-8691-59	Motor Overload
TB1	794-8626-01	794-8626-01	Terminal Barrier
CR1	794-8625-15	794-8625-15	Relay
CR2	794-8625-15	794-8625-15	Relay
CR3	794-8625-15	794-8625-15	Relay
SR1	794-8687-79	794-8687-79	Strain Relief
SR2	794-8144-03	794-8144-03	Strain Relief
SR3	800-8014-69	800-8014-71	Strain Relief
SR4	800-8014-69	800-8014-71	Strain Relief
SR5	800-8014-69	800-8014-71	Strain Relief
SR6	800-8014-69	800-8014-71	Strain Relief
SR7	800-8014-71	800-8014-71	Strain Relief
SRN3	800-8667-93	800-8667-93	Strain Relief Nut
SRN4	800-8667-93	800-8667-93	Strain Relief Nut
SRN5	800-8667-93	800-8667-93	Strain Relief Nut
SRN6	800-8667-93	800-8667-93	Strain Relief Nut
SRN7	800-8667-93	800-8667-93	Strain Relief Nut
PCTB	794-8016-71	794-8016-71	Printed Circuit Board
FB4	794-8142-66	794-8142-66	Fuse Holder
F4	794-8119-78	794-8119-78	Fuse

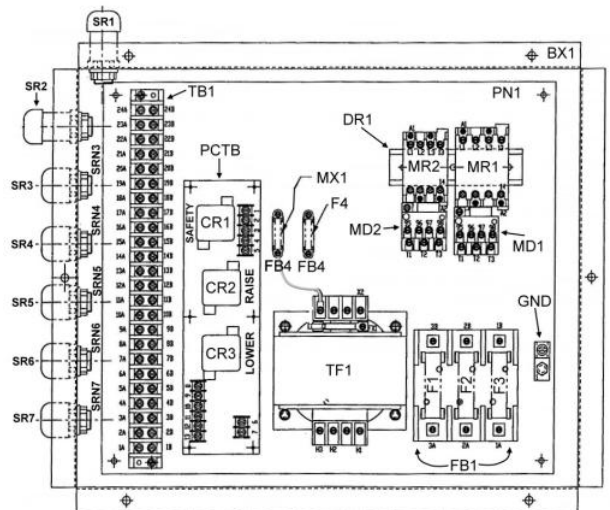

FG5000/FG10000 Flywheel Grinder

CONTROL BOX ASSEMBLY MACHINE MODEL NUMBERS / VOLTS / HZ / PHASE

794-8688-06 - FG10000 208-230/60/3 PAG 794-8688-50 - FG5000 208-230/60/3 PAG
794-8688-38 - FG10000 460/60/3 PAG 794-8688-53 - FG5000 460/60/3 PAG

ITEM	794-8688-06 PART #	794-8688-38 PART #	794-8688-50 PART #	794-8688-53 PART #	DESCRIPTION
BX1	794-8687-77	794-8687-77	794-8687-77	794-8687-77	Control Board
PN1	794-8687-78	794-8687-78	794-8687-78	794-8687-78	Panel
DR1	794-8687-72	794-8687-72	794-8687-72	794-8687-72	Din Rail
*GND	794-8142-14	794-8142-14	794-8142-14	794-8142-14	Ground lug
FB1	794-8686-75	794-8180-16	794-8132-70	794-8180-16	Fuse Holder
F1	794-8633-68	794-8688-72	794-8132-69	794-8659-98	Fuse
F2	794-8633-68	794-8688-72	794-8132-69	794-8659-98	Fuse
F3	794-8633-68	794-8688-72	794-8132-69	794-8659-98	Fuse
TF1	794-8676-78	794-8623-17	794-8676-78	794-8623-17	Transformer
FX1	794-1421-17	794-1421-17	794-1421-17	794-1421-17	Fuse
BR1	794-8687-76	794-8687-76	794-8687-76	794-8687-76	Bridge Rectifier
MR1	794-8691-47	794-8691-46	794-8691-46	794-8691-46	Motor Relay
MO1	794-8691-55	794-8691-63	794-8691-63	794-8691-51	Motor Overload
MR2	794-8691-45	794-8691-45	794-8691-45	794-8691-45	Motor Relay
MO2	794-8691-57	794-8691-59	794-8691-57	794-8691-59	Motor Overload
RS4	794-8687-73	794-8687-73	794-8687-73	794-8687-73	Relay Socket
RS5	794-8687-73	794-8687-73	794-8687-73	794-8687-73	Relay Socket
TB1	794-8626-01	794-8626-01	794-8626-01	794-8626-01	Terminal Barrier
CR1	794-8625-15	794-8625-15	794-8625-15	794-8625-15	Relay
CR2	794-8625-15	794-8625-15	794-8625-15	794-8625-15	Relay
CR3	794-8625-15	794-8625-15	794-8625-15	794-8625-15	Relay
CR4	794-8625-15	794-8625-15	794-8625-15	794-8625-15	Relay
CR5	794-8625-15	794-8625-15	794-8625-15	794-8625-15	Relay
CS1	794-8687-74	794-8687-74	794-8687-74	794-8687-74	Current Sensor
SR1	794-8687-79	794-8687-79	794-8687-79	794-8687-79	Strain Relief
SR2	794-8687-79	794-8687-79	794-8687-79	794-8687-79	Strain Relief
SR3	794-8144-03	794-8144-03	794-8144-03	794-8144-03	Strain Relief
SR4	800-8014-71	800-8014-71	800-8014-71	800-8014-71	Strain Relief
SR5	800-8014-71	800-8014-71	800-8014-71	800-8014-71	Strain Relief
SR6	800-8014-71	800-8014-71	800-8014-71	800-8014-71	Strain Relief
SR7	800-8014-71	800-8014-71	800-8014-71	800-8014-71	Strain Relief
SRN3	800-8667-93	800-8667-93	800-8667-93	800-8667-93	Strain Relief Nut
SRN4	800-8667-93	800-8667-93	800-8667-93	800-8667-93	Strain Relief Nut
SRN5	800-8667-93	800-8667-93	800-8667-93	800-8667-93	Strain Relief Nut
SRN6	800-8667-93	800-8667-93	800-8667-93	800-8667-93	Strain Relief Nut
SRN7	800-8667-93	800-8667-93	800-8667-93	800-8667-93	Strain Relief Nut
PCTB	794-8016-71	794-8016-71	794-8016-71	794-8016-71	Printed Circuit Board

*460v machines have the second GND near the terminal strip for CSA compliance

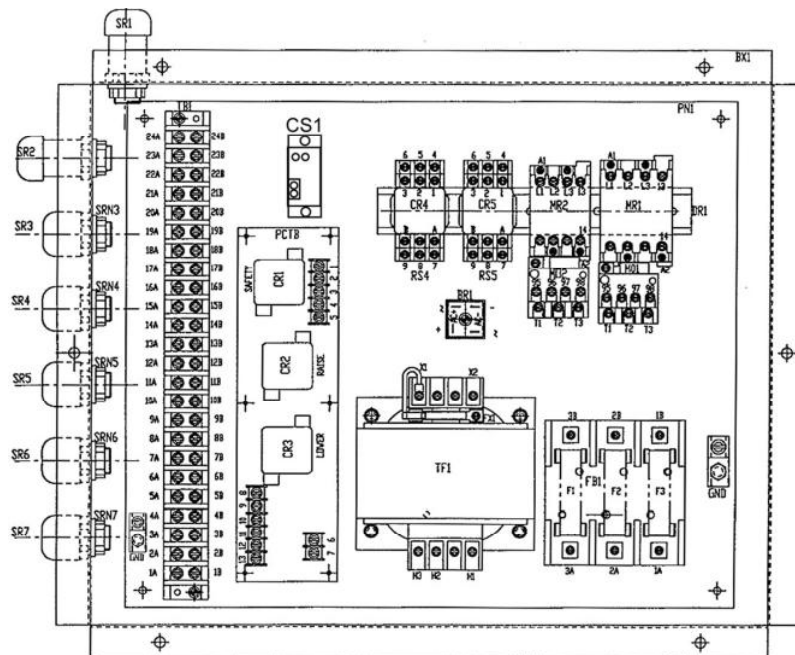

CONTROL BOX ASSEMBLY
MACHINE MODEL NUMBERS / VOLTS / HZ / PHASE

794-8688-51 -- FG5000 208-230/60/1 PAG

ITEM	PART #	DESCRIPTION
BX1	794-8687-77	Control Box
PN1	794-8687-78	Panel
DR1	794-8687-72	Din Rail
GND	794-8142-14	Ground Lug
FB1	794-8624-11	Fuse Holder
F1	794-8633-68	Fuse
F2	794-8633-68	Fuse
F3	794-1421-17	Fuse
F4	794-1421-17	Fuse
BR1	794-8687-76	Bridge Rectifier
MR1	794-8691-47	Motor Relay
MO1	794-8691-56	Motor Overload
MR2	794-8691-45	Motor Relay
MO2	794-8691-58	Motor Overload
RS1	794-8687-73	Relay Socket
RS2	794-8687-73	Relay Socket
RS4	794-8687-73	Relay Socket
RS5	794-8687-73	Relay Socket
TB1	794-8626-01	Terminal Barrier
CR1	794-8625-15	Relay
CR2	794-8625-15	Relay
CR4	794-8625-15	Relay
CR5	794-8625-15	Relay
CS1	794-8687-74	Current Sensor
SR1	794-8687-79	Strain Relief
SR2	794-8144-03	Strain Relief
SR3	794-8144-03	Strain Relief
SR4	800-8014-71	Strain Relief
SR5	800-8014-71	Strain Relief
SR6	800-8014-71	Strain Relief
SR7	800-8014-71	Strain Relief
SRN3	800-8667-93	Strain Relief Nut
SRN4	800-8667-93	Strain Relief Nut
SRN5	800-8667-93	Strain Relief Nut
SRN6	800-8667-93	Strain Relief Nut
SRN7	800-8667-93	Strain Relief Nut
FB3	794-8142-66	Fuse Holder
FB4	794-8142-66	Fuse Holder
AC1	794-8688-93	Auxiliary Control
DR2	794-8014-10	Din Rail

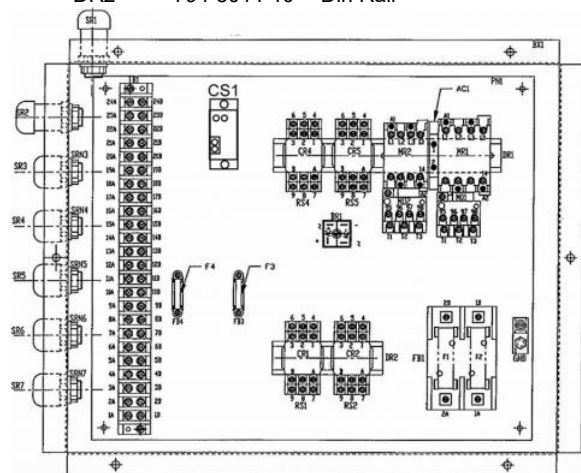

794-8688-37 -- FG10000 380/50/3 PAG
794-8688-52 -- FG5000 380/50/3 PAG

ITEM	PART #	PART #	DESCRIPTION
BX1	794-8687-77	794-8687-77	Control Box
PN1	794-8687-78	794-8687-78	Panel
DR1	794-8687-72	794-8687-72	Din Rail
GND	794-8142-14	794-8142-14	Ground Lug
FB1	794-8180-16	794-8180-16	Fuse Holder
F1	791-8688-72	794-8659-98	Fuse
F2	791-8688-72	794-8659-98	Fuse
F3	791-8688-72	794-8659-98	Fuse
TF1	794-8677-74	794-8677-74	Transformer
FX1	794-8119-78	794-8119-78	Fuse
BR1	794-8687-76	794-8687-76	Bridge Rectifier
MR1	794-8691-46	794-8691-46	Motor Relay
MO1	794-8691-63	794-8691-51	Motor Overload
MR2	794-8691-45	794-8691-45	Motor Relay
MO2	794-8691-59	794-8691-59	Motor Overload
RS4	794-8687-73	794-8687-73	Relay Socket
RS5	794-8687-73	794-8687-73	Relay Socket
TB1	794-8626-01	794-8626-01	Terminal Barrier
CR1	794-8625-15	794-8625-15	Relay
CR2	794-8625-15	794-8625-15	Relay
CR4	794-8625-15	794-8625-15	Relay
CR5	794-8625-15	794-8625-15	Relay
CS1	794-8687-74	794-8687-74	Current Sensor
SR1	794-8687-79	794-8687-79	Strain Relief
SR2	794-8144-03	794-8144-03	Strain Relief
SR3	794-8144-03	794-8144-03	Strain Relief
SR4	800-8014-71	800-8014-71	Strain Relief
SR5	800-8014-71	800-8014-71	Strain Relief
SR6	800-8014-71	800-8014-71	Strain Relief
SR7	800-8014-71	800-8014-71	Strain Relief
SRN3	800-8667-93	800-8667-93	Strain Relief Nut
SRN4	800-8667-93	800-8667-93	Strain Relief Nut
SRN5	800-8667-93	800-8667-93	Strain Relief Nut
SRN6	800-8667-93	800-8667-93	Strain Relief Nut
SRN7	800-8667-93	800-8667-93	Strain Relief Nut
PCTB	794-8016-71	794-8016-71	Printed Circuit Board
FB4	794-8142-66	794-8142-66	Fuse Holder
F4	794-8119-78	794-8119-78	Fuse

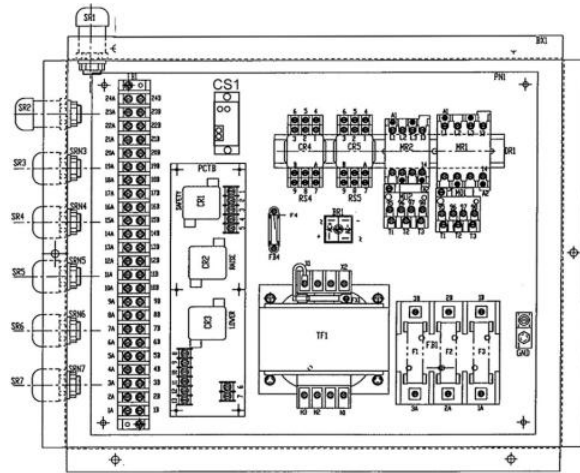

COMMON CONTROL BOX COMPONENT IDENTIFICATION

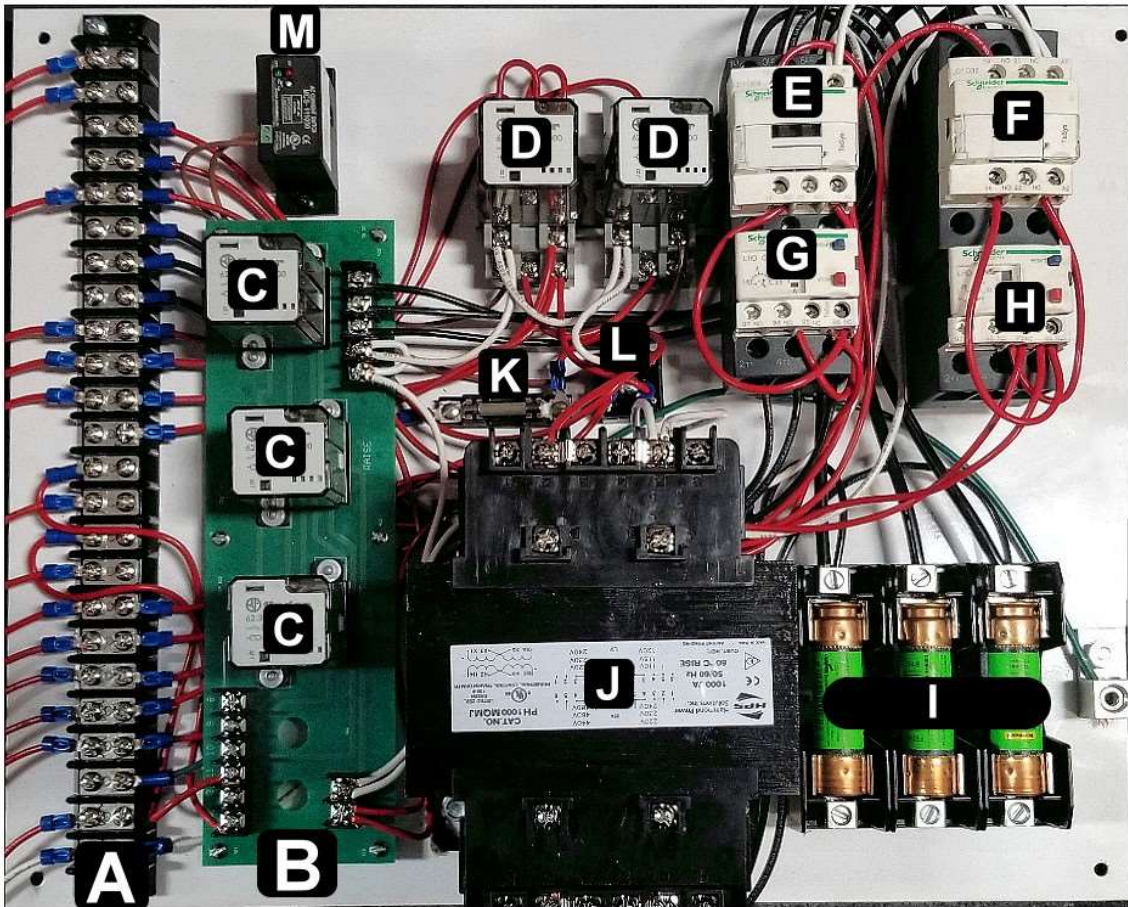

ID	PART #	DESCRIPTION
A	794-8626-01	Terminal Block Strip (TB1 is on the bottom then count up, TB2, TB3, etc.) A on the left
B	794-8016-71	Printed Circuit Board
C	794-8625-15	Relay for Power Column (3)
D	794-8625-15	Relay for Auto Grind (2)
E	794-8691-45	Table Motor Contactor
F	794-8691-46 / 47	Grinding Motor Contactor (794-8691-46 - FG5000), (794-8691-47 - FG10000)
G	794-8691-57	Table Motor Overload Relay
H	794-8691-63 / 54	Grinding Motor Overload Relay (794-8691-63 – FG5000), (794-8691-54 – FG10000)
I	794-8132-69 / 68	Fuse (3) 220x3 (794-8132-69 – FG5000, 30 Amp), (794-8132-68 – FG10000, 60 Amp)
J	794-8676-78	Transformer
K	794-1421-17	7 Amp Fuse (under the K)
L	794-8687-76	Bridge Rectifier
M	794-8687-74	Auto-Grind Current Sensor

FG5000/FG10000 Flywheel Grinder

WIRING DIAGRAM
MACHINE MODEL NUMBERS
794-8690-00, 794-8690-02, 794-8690-08

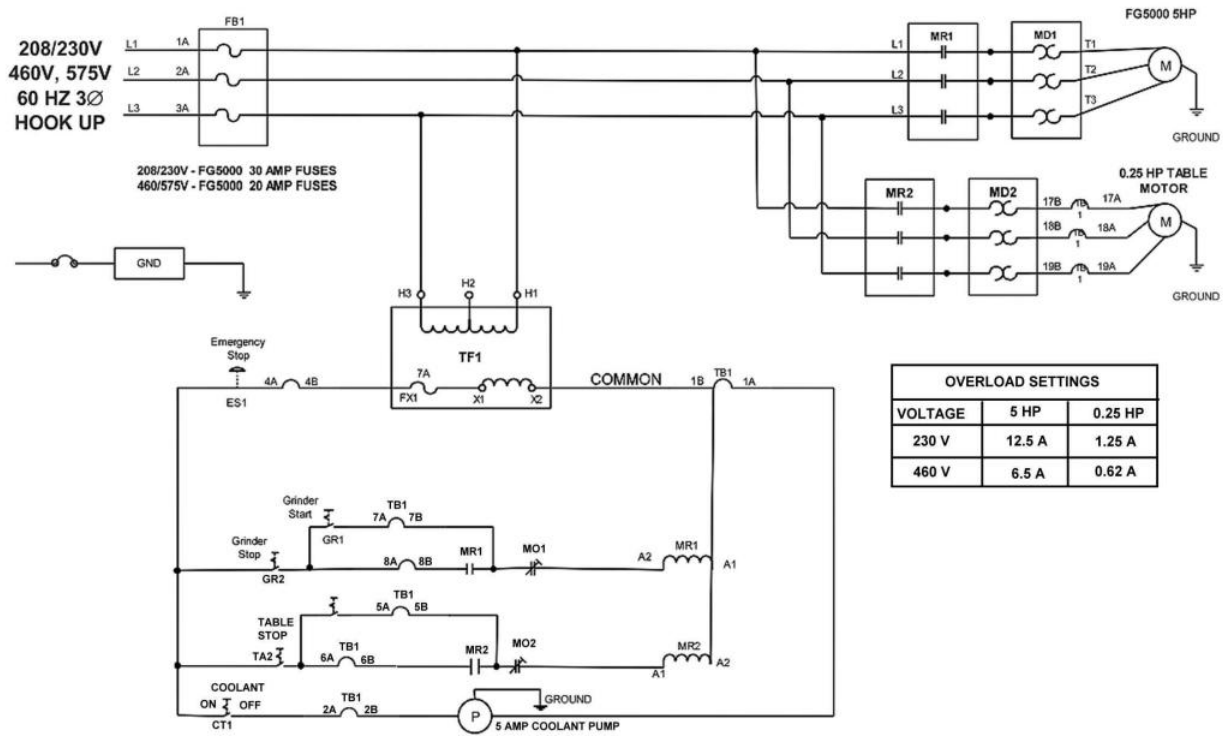

WIRING DIAGRAM
MACHINE MODEL NUMBER
794-8690-01

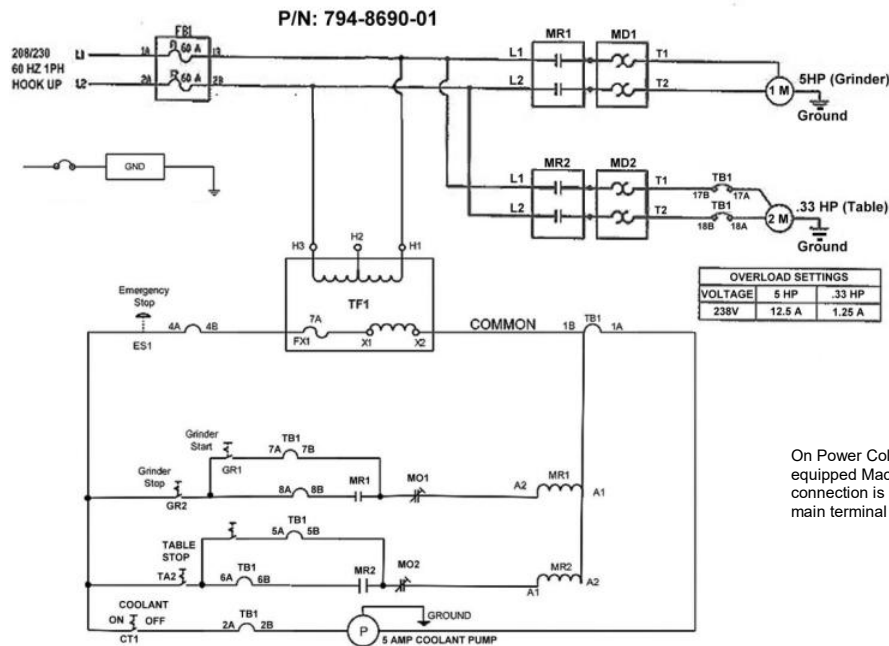

On Power Column & Auto-Grind equipped Machines the Common connection is on the bottom of the main terminal block on the left.

FG5000/FG10000 Flywheel

**MACHINE MODEL NUMBER
794-8690-03**

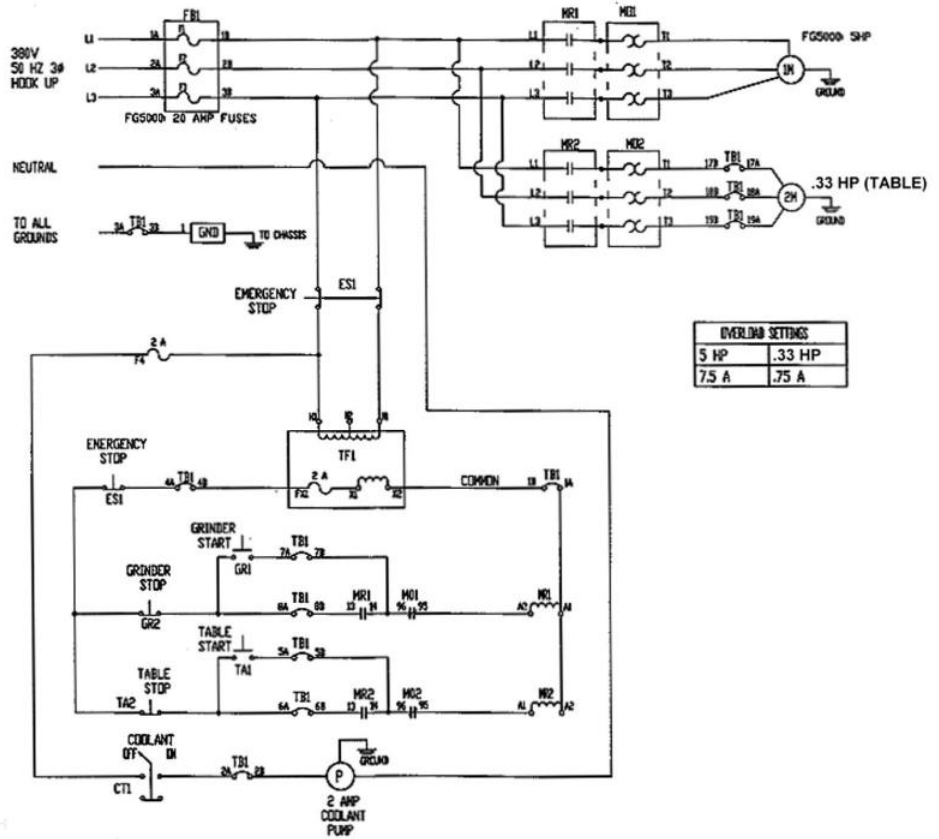

**MACHINE MODEL NUMBER
794-8688-41**

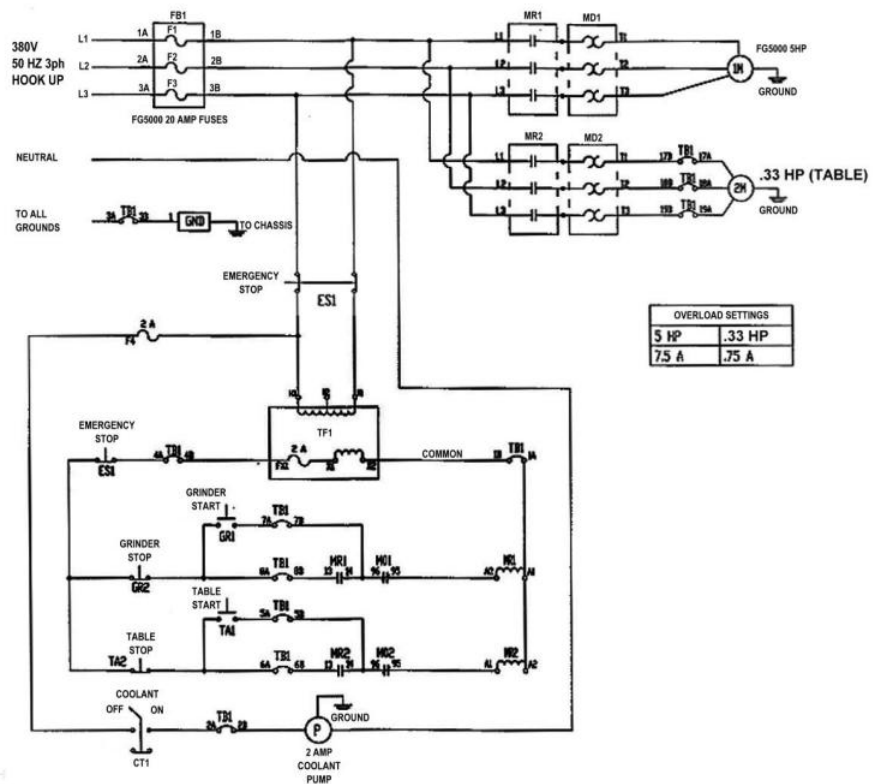

WIRING DIAGRAM
MACHINE MODEL NUMBERS
 794-8688-35, 794-8688-42

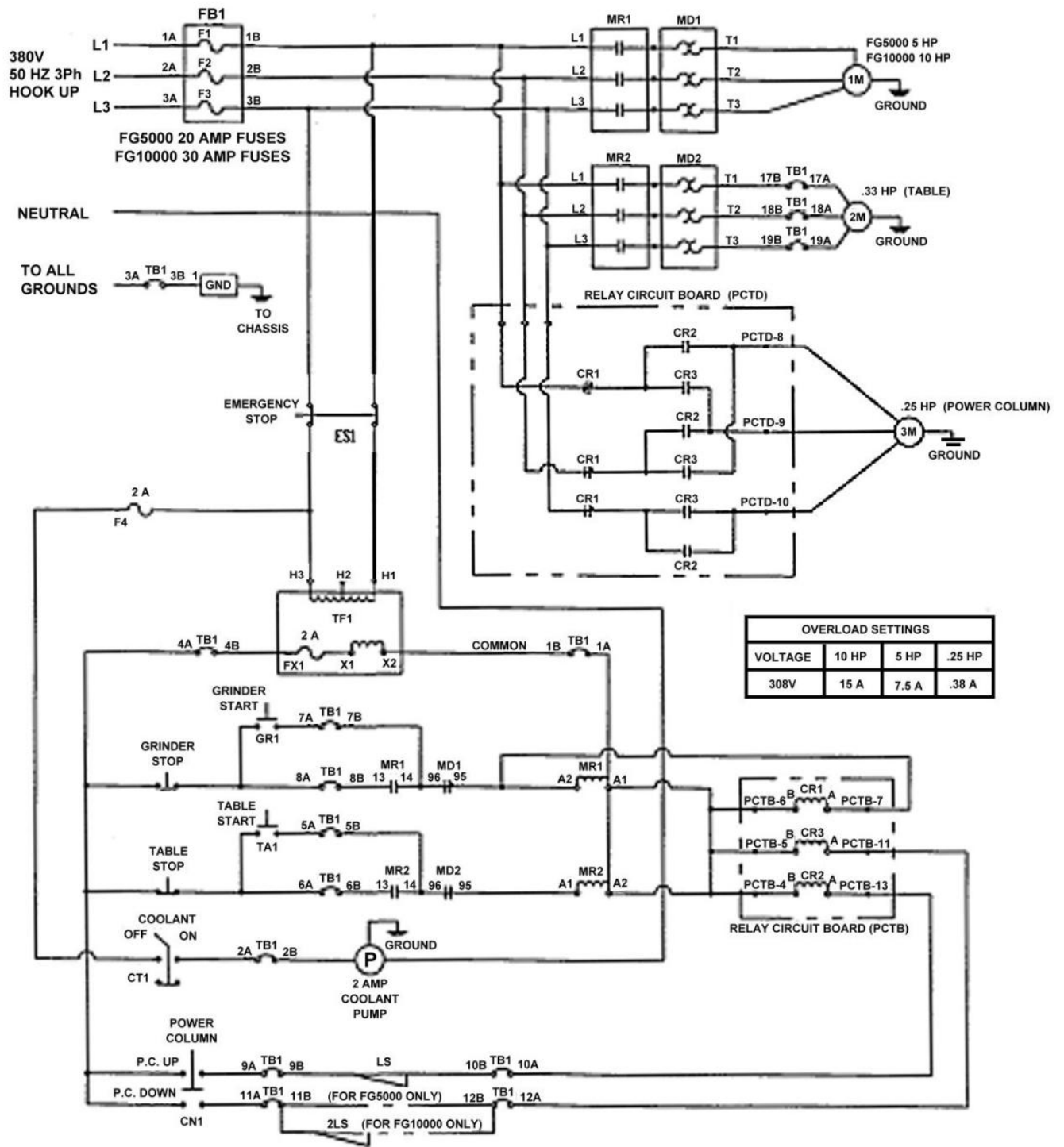

WIRING DIAGRAM
MACHINE MODEL NUMBERS
 794-8688-40, 794-8688-43,
 794-8688-22, 794-8688-36

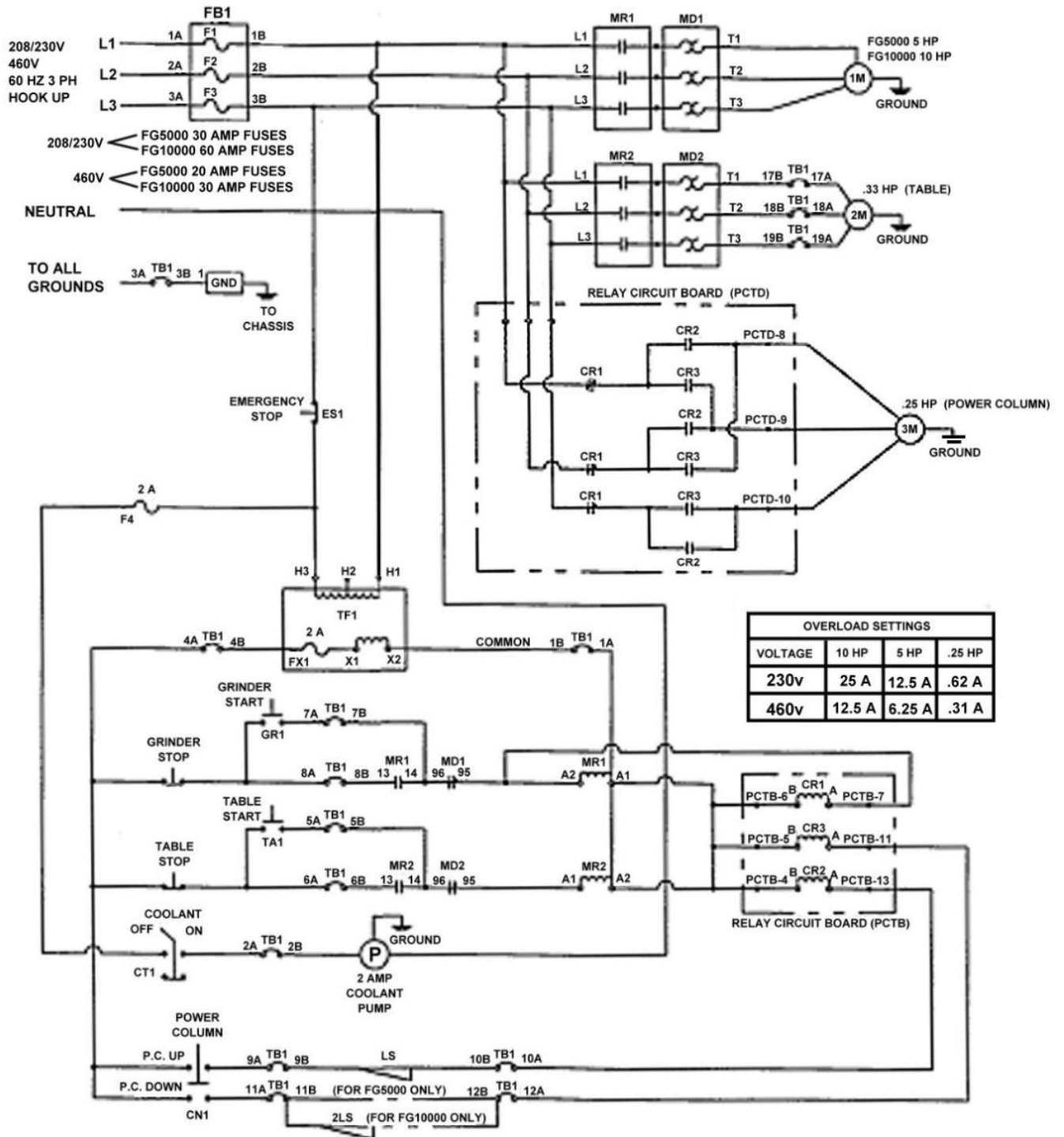

WIRING DIAGRAM
MACHINE MODEL NUMBERS
 794-8688-06, 794-8688-38, 794-8688-50, 794-8688-53

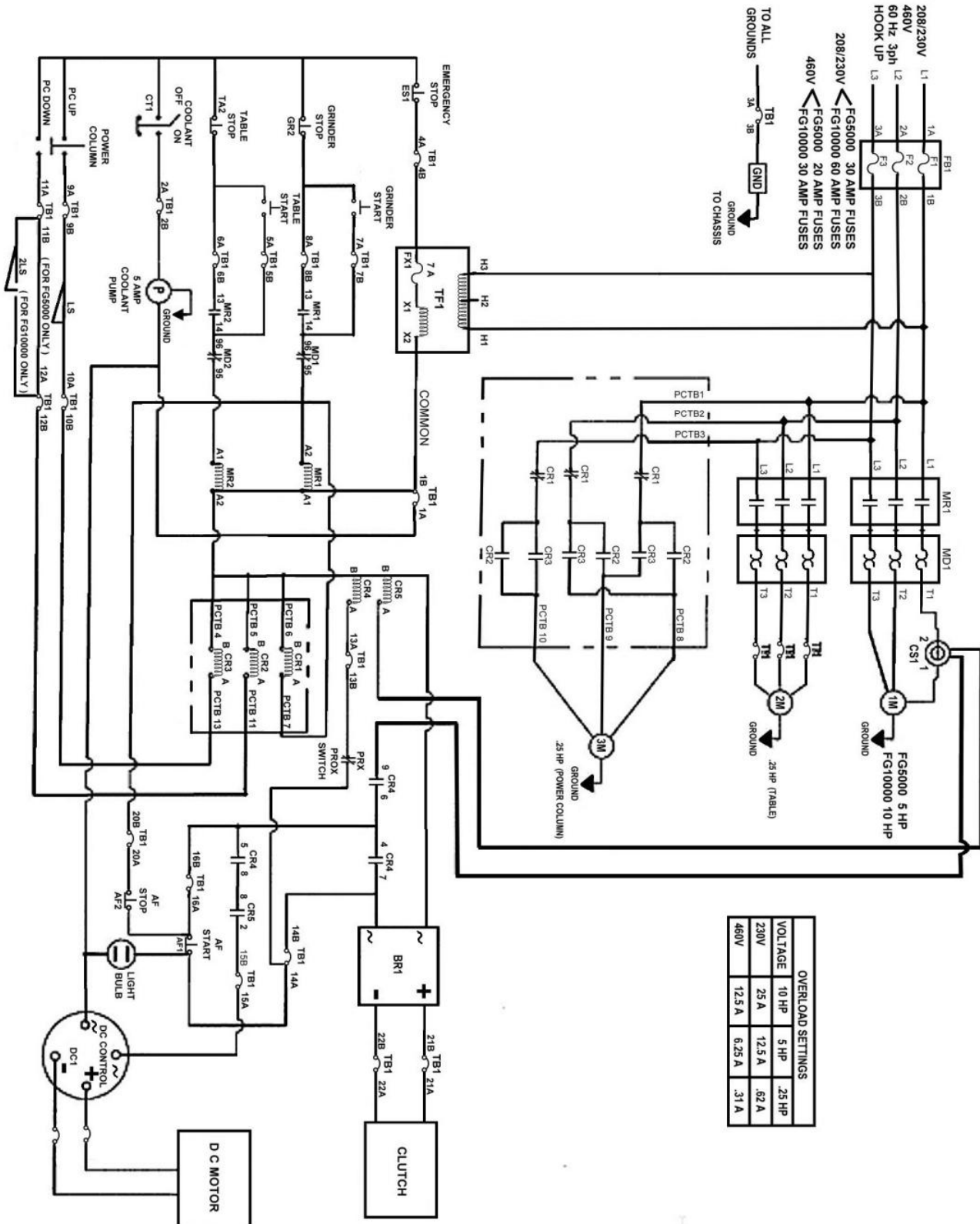

CONTROL BOX ASSEMBLY MACHINE MODEL NUMBERS 794-8688-37, 794-8688-52

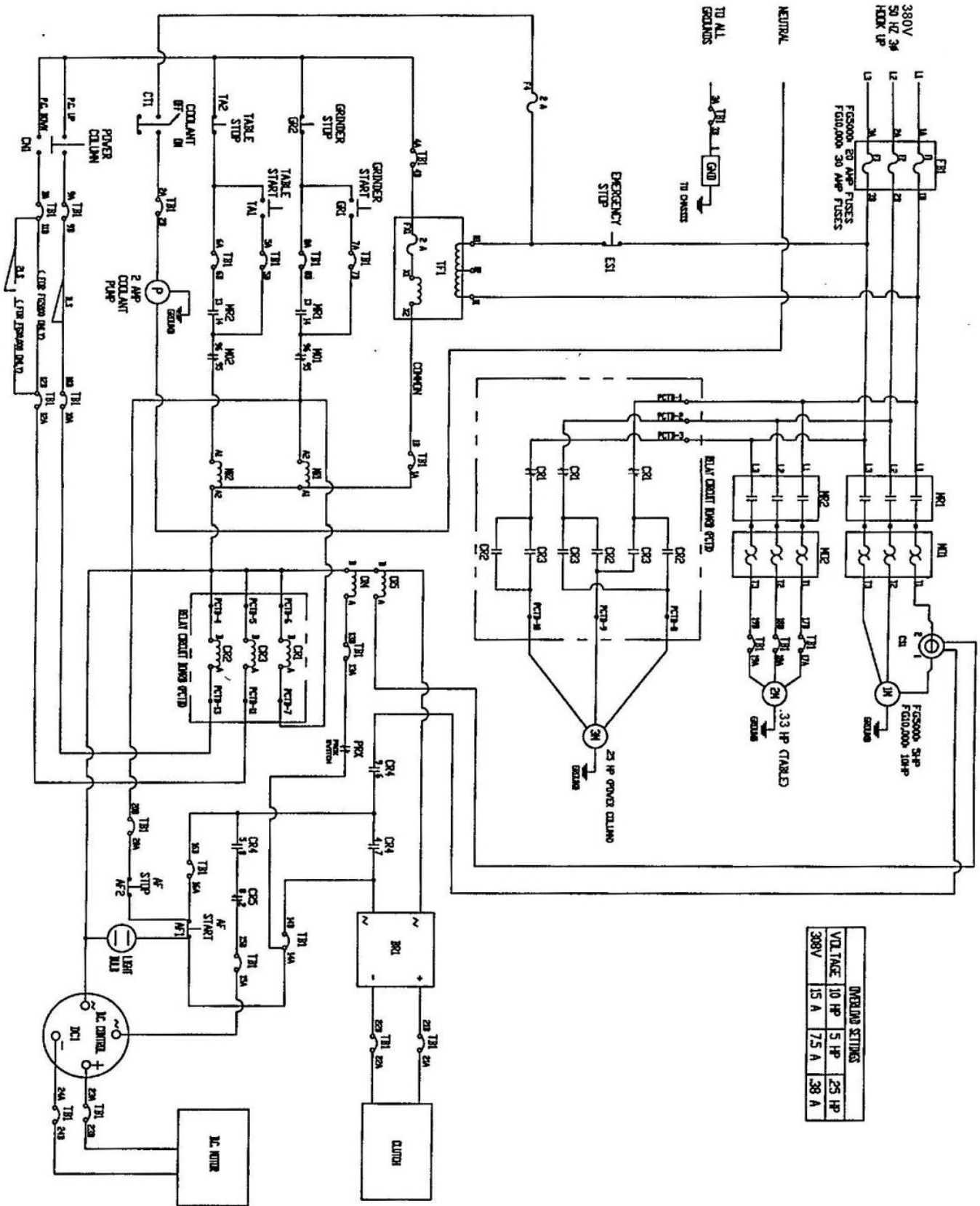



Irontite Products Inc.

Van Norman Brand

PO Box 9877, Cedar Rapids, IA 52409 USA

800-553-5953

+1-319-377-9421

319-377-9101 (FAX)

www.van-norman.com

service@irontite.com