



**BY IRONTITE**

**The Kwik-Way Centerline System**



**Exclusive Six-ball Chuck Design**



# **Model SVS II Deluxe (SVSII-D) Valve Refacer**

**ORIGINAL INSTRUCTION MANUAL AND PARTS LIST**



MANUFACTURER OF IRONTITE, VAN NORMAN, AND KWIK-WAY BRAND PRODUCTS  
Irontite Products Inc. 2525 18<sup>th</sup> Street SW, Suite D, Cedar Rapids, IA 52409 USA 800-553-5953 +1-319-377-9421

[www.kwik-way.com](http://www.kwik-way.com)

[www.irontite.com](http://www.irontite.com)

[www.van-norman.com](http://www.van-norman.com)

Copyright © 2024 by Irontite Products Inc. All Rights Reserved. Rev. 241025 CE PN: 009-1500-04  
Equipment specifications, options and accessories subject to change without notice



## KWIK-WAY SIX BALL "CENTERLINE" CHUCK SYSTEM

Your **Kwik-Way SVSII Valve Refacer** is an American classic. For over 100 years, the **Kwik-Way Valve Refacer** has been the staple of the engine rebuilding industry. The heart of this precision and accuracy is the Kwik-Way designed six ball chuck that is air activated and self-aligning.



### Air Operated Six Ball Chuck

**Consistent Accuracy** - 2 sets of 3 balls automatically find the existing valve stem centerline to assure valve grinding accuracy. Accuracy to within .0002" with High Performance Chuck.

**Impressive Speed** - The chuck is air activated to open quickly to its full diameter at the touch of a button. Operators can work through a wide range of valve sized without stopping to change collets.

**Full Range** - Valve stems from 4mm to 14.3mm (11mm to 21mm with the large chuck option)

The **Kwik-Way 6 ball Centerline Chuck** will provide years of accurate valve grinding with some simple rules of use and proper maintenance. This Precision made tool is important to keep clean. Failing to get into good machine use habits could affect the accuracy of the chuck.

- **NEVER USE ANY LUBRICANT IN THE CHUCK.** Only use ATF (Automatic Transmission Fluid or Denatured Alcohol)
- **COVER THE CHUCK WHEN NOT IN USE.** Especially when dressing the grinding wheel or when the machine is not in use. The Chuck Cover (012-1050-12) is included with each machine for this purpose.
- **ENSURE VALVE STEMS ARE CLEAN AND FREE OF CARBON.**

Should the chuck become dirty, disassemble and clean the chuck using only Denatured Alcohol and ATF. Follow the instructions provided in the machine manual.



Machine manual  
download page

Chuck disassembly  
& assembly video



## PURCHASER'S WARRANTY

### ***Irontite Products Inc.***

***Manufacturer of Kwik-Way, Van Norman, and Irontite Brands***

***PO Box 9877,***

***Cedar Rapids, IA 52409-9877 USA***

**The Company** guarantees all parts of its equipment, to the original purchaser, for three full years (one year electrical) from date of recorded warranty (except as provided below) against defects in material or workmanship when the equipment is installed in strict accordance with pertinent specifications and procedures.

**The Company** will repair and/or replace free of charge all such defective parts only when returned to the factory in Cedar Rapids, **with shipping charges prepaid and authorized RMA**. To obtain an RMA, contact Customer Service at +1-319-377-9421 (service@kwik-way.com)

This warranty does not cover damage caused by accident, abuse or improper installation, nor repair or replacement of parts worn or consumed in normal operation of the machine.

Additionally, this warranty does not cover the following items; dresser diamonds, ball bearings, grinding wheels, belts, carbide tool bits, and other accessory items, except at the full discretion of the company. **The warranty on electric motors or electrical component parts is for a period of one year from date of delivery.**

This warranty is at no time intended to mean the entire machine.

## RECEIVING SHIPMENT

Upon taking delivery of your machine, carefully inspect the assembly before removing the crating and packing materials. If evidence of damage exists, TAKE PHOTOS, and contact the shipper and ***Irontite Products Inc.*** immediately.

Although ***Irontite Products Inc.*** is not responsible for damage incurred during transit, you will be provided assistance in preparation and filing of any necessary claims.

**CAREFULLY READ THIS MANUAL BEFORE ATTEMPTING TO SETUP OR OPERATE THIS MACHINE.**

### ATTENTION:

Any time this machine is removed from power (unplugged) it will not function until the POWER LOSS RESET BUTTON is pressed to re-engage the power system. (see CONTROLS & SWITCHES for more)

### IMPORTANT NOTE

Always have your serial number ready when communicating with ***Irontite Products Inc.*** regarding parts or service. Keep this manual in a safe place.

DECLARATION OF CONFORMITY:

# EU DECLARATION OF CONFORMITY

**Irontite Products Inc.  
2525 18<sup>th</sup> Street SW, Suite D  
Cedar Rapids, IA. 52404 USA**

**Name and address of the company established in European Union and authorized to compile the Technical File:**

**ACC- Services Contact  
78 Allee Primavera  
Centre Ubidoca 2402  
74370 Annecy FRANCE**

**IRONTITE PRODUCTS INC. declares under our sole responsibility that the product described as:**

**Equipment Name: Kwik-Way Valve Refacer / Grinder  
Model / Type: KWIK-WAY SVSIID 230-50-1**

**Serial number (s) \_\_\_\_\_**

**Complies with the requirements of the following European Directives:**

**Machinery Directive 2006/42/EC;  
Electromagnetic Compatibility Directive 2014/30/EU.**

**Main Standards Considered:**

**EN ISO 12100:2010, EN ISO 16089:2015  
EN 60204-1:2018, EN ISO 13849-1:2023  
EN 61000-6-2:2019, EN 61000-6-4:2019**

**Date: \_\_\_\_\_**

**At: Cedar Rapids, Iowa USA**

**Name and title of Authorized company representative: Mr. Mitch Malcolm  
VP Global Sales**

**Signature: \_\_\_\_\_**

## SAFETY FIRST

This manual has been prepared for the owner and those responsible for the maintenance of this machine. Its purpose aside from proper maintenance and operations, is to promote safety through the use of accepted practice. **READ THE SAFETY AND OPERATING INSTRUCTIONS THOROUGHLY BEFORE OPERATING THE MACHINE.**

In order to obtain maximum life and efficiency from your machine, follow all the instructions in the operating manuals carefully.

The specifications put forth in this manual were in effect at the time of publication. However, owing to the Company's policy of continuous improvement, changes to these specifications may be made at any time without obligation.

Read All Documentation	Use Safety Guards	Electrically Gound Machine	Confine Loose Clothing / Hair	Do Not Wear Watches / Jewelry
				
				
Wear Safety Glasses / Shield	Keep Area Dry And Clean	Turn Off Before Cleaning / Adjusting	Do Not Wear Gloves	Tighten Work Piece Securely

**ATTENTION:**  
 Any time this machine is removed from power (unplugged) it will not function until the **POWER LOSS RESET BUTTON** is pressed to re-engage the power system. (see **CONTROLS & SWITCHES** for more)

## SAFETY INSTRUCTIONS

1. Read, understand and follow the safety and operating instructions found in this manual. Know the limitations and hazards associated with operating the machine.
2. **Eye Safety:** Wear an approved safety face shield, goggles or safety glasses to protect eyes when operating the machine.
3. **Grounding the Machine:** Machines equipped with three prong grounding plugs are so equipped for your protection against shock hazards and should be plugged directly into a properly grounded three-prong receptacle in accordance with national electrical codes and local codes and ordinances. A grounding adapter may be used. If one is used, the green lead should be securely connected to a suitable electrical ground such as a ground wire system. Do not cut off the grounding prong or use an adapter with the grounding prong removed.
4. **Work Area:** Keep the floor around the machine clean and free of tools, tooling, stock scrap and other foreign material and oil, grease or coolant to minimize the danger of tripping or slipping. The Company recommends the use of anti-skid floor strips on the floor area where the operator normally stands and that each machine's work area be marked off. Make certain the work area is well lighted and ventilated. Provide for adequate workspace around the machine.
5. **Guards:** Keep all machine guards in place at all times when machine is in use.
6. **Do Not Overreach:** Maintain a balanced stance and keep your body under control at all times.
7. **Hand Safety:** NEVER wear gloves while operating this machine.
8. **Machine Capacity:** Do not attempt to use the machine beyond its stated capacity or operations. This type of use will reduce the productive life of the machine and could cause the breakage of parts, which could result in personal injury.
9. **Avoid Accidental Starting:** Make certain the main switch is in the OFF position before connecting power to the machine.
10. **Careless Acts:** Give the work you are doing your undivided attention. Looking around, carrying on a conversation and horseplay are careless acts that can result in serious injury.
11. **Job Completion:** If the operation is complete, the machine should be emptied and the work area cleaned.
12. **Disconnect All Power and Air to Machine** before performing any service or maintenance.
13. **Replacement Parts:** Use only Kwik-Way replacement parts and accessories (manufactured by Irontite Products Inc.); otherwise, warranty will be null and void.
14. **Misuse:** Do not use the machine for other than its intended use. If used for other purposes, the Company disclaims any real or implied warranty and holds itself harmless for any injury or loss that may result from such use.
15. The Kwik-Way Valve Refacing Machine is designed and intended for use in automotive repair and machine shops. It is specifically used to restore worn or damaged engine valves to their original specifications. The machine is capable of grinding valve faces to precise tolerances, ensuring proper sealing and performance of the engine's combustion chamber.



**Important Note:** This machine is intended for use by qualified professionals with experience in engine repair and machine shop operations. Improper use of this equipment can result in injury or damage to the machine or the valves being worked on. Always consult the machine's operating manual for specific instructions and safety guidelines.

## SAFETY GUIDE FOR VALVE GRINDER WHEELS

(Read before installing the Grinding Wheels)

### IMPORTANCE OF PROPER MACHINE MAINTENANCE

The most common cause of wheel breakage is due to improper mounting and abusive and/or careless operation. Only through proper use, regular machine maintenance, service, and inspection procedures can wheel breakage be prevented.

It is the responsibility of the user to inspect, at regular intervals, to be certain that mounting flanges are in usable condition, are of proper size and shape and that no damage has occurred to the wheel or the machine.

The following **DO'S** and **DON'TS** should be used as a guide to safer grinding.

#### **WARNING: IMPROPER USE MAY CAUSE BREAKAGE AND SERIOUS INJURY.**

<b>DO</b>	<b>DON'T</b>
<b>DO:</b> CHECK all wheels for CRACKS or other DAMAGE before mounting.	<b>DON'T:</b> USE wheels WHICH HAVE BEEN DROPPED or otherwise damaged.
<b>DO:</b> USE MOUNTING BLOTTERS. Most modern wheels are supplied with blotters attached. If not, it is your responsibility to use appropriate mounting blotters.	<b>DON'T:</b> USE EXCESSIVE PRESSURE WHEN MOUNTING the wheel between flanges. Tighten the nut only enough to hold the wheel firmly.
<b>DO:</b> be sure the WHEEL HOLE, threaded or unthreaded, FITS the machine arbor PROPERLY and that flanges are clean, flat, and of the proper type for the wheel you are mounting.	<b>DON'T:</b> USE HEAVY GRINDING PRESSURE.
<b>DO:</b> always RUN THE WHEEL WITH THE GUARD IN PLACE at least one minute before grinding with it.	<b>DON'T:</b> USE THE MACHINE FOR ANY PURPOSE OTHER THAN GRINDING VALVES, VALVE STEMS OR ROCKER ARMS.
<b>DO:</b> USE THE WHEEL GUARD furnished with the machine.	<b>DON'T:</b> Operate the machine while wearing any baggy or loose clothing.
<b>DO:</b> always WEAR PROTECTIVE SAFETY GLASSES or FACE SHIELD.	<b>DON'T:</b> Use any cleaning chemicals that can leave a film or any residue as this will affect the performance of your chuck. The Collar and Balls area of the <b>Chuck should only be lubricated with Automatic Transmission Fluid</b> and NOTHING ELSE. And only <b>clean the chuck with Denatured Alcohol</b> .

## WARNINGS AND CAUTIONS

- WARNING:** Improper use may cause breakage and serious injury.
- WARNING:** Always disconnect the machine from the power source before attempting to change wheels.
- WARNING:** NEVER dress the wheel without first covering the chuck.
- WARNING:** DO NOT draw the wheel off the valve. Move the valve away first.
- WARNING:** NEVER attempt to release or remove the valve from the chuck while either motor is still running.
- WARNING:** NEVER attempt to remove the valve from the V-block while grinding wheel is still turning.
- WARNING:** DO NOT attempt to remove the rocker arm while grinding wheel is still turning.
- WARNING:** Disconnect the machine from its power source BEFORE beginning any adjustments.
- WARNING:** Disconnect the machine from its power source before cleaning the chuck.
- WARNING:** *Never use any penetrating oil or cleaning solutions on your chuck.*  
ONLY LUBRICATE WITH AUTOMATIC TRANSMISSION FLUID on the collar and ball area of the chuck.
- WARNING:** To clean the chuck, you must disassemble it using the provided tool and ONLY use denatured alcohol to clean. Then lubricate during re-assembly with ATF.
- CAUTION:** Be certain that the machine is properly grounded.
- CAUTION:** DO NOT stop rocker arm movement while shoe is in contact with the grinding wheel. If rocker arm is allowed to dwell in one location, a flat spot will occur.
- CAUTION:** When adjusting belt tension, DO NOT over-tighten.
- CAUTION:** Dirty grinding oil can damage the pump and affect grind quality.

## SPECIFICATIONS

Specifications	Standard	Metric
Minimum Chuck Capacity (Valve Stem Diameter)	5/32"	4mm
Maximum Chuck Capacity (Valve Stem Diameter)	9/16"	14 mm
Minimum Valve Stem Length (approx.)	3.375"	85.73 mm
Maximum Valve Head Diameter	4"	100 mm
Valve Grinding Wheel Diameter	7"	178 mm
Surface Wheel Diameter	3"	76 mm
Spindle Drive Motor (H.P.)	1/2	0.37 KW
Chuck Drive Motor (H.P.)	1/20	0.04 KW
Grinding Oil Capacity	1 Gallon	3.8 Liter
Chuck R.P.M. (approx.)	100 to 300	
Grinding Angles	From 13 to 62 degrees	
Overall Length	37"	940 mm
Overall Width	22"	559 mm
Overall Height	16"	406 mm
Shipping Weight	310 lbs.	141 kg
Vibration to hand (is less than)	$2.5/S^2$	
Noise Level	60 dBs	
Air Pressure	65 psi	4.5 bar

### *Stay Updated with kwik-way.com*

For the latest information and support on your machine, visit [kwik-way.com](http://kwik-way.com).

- **Free Manual Downloads:** Find the most recent version of this manual.
- **Replacement Parts:** View photos, descriptions, and pricing for common replacement parts.
  - **International Customers:** Contact International Sales at +1 319-377-9421 or [international@kwik-way.com](mailto:international@kwik-way.com).
- **Helpful Resources:** Access videos and blog articles for tips, troubleshooting, and best practices.

STANDARD ACCESSORIES WITH THE SVS II DELUXE

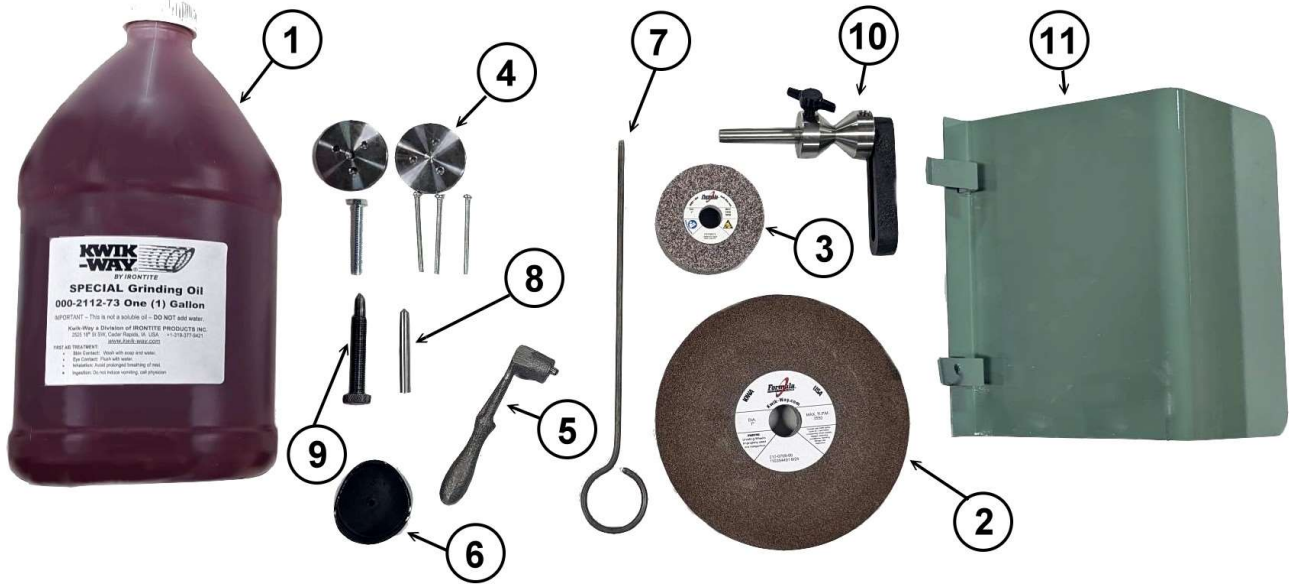

Image #	DESCRIPTION	PART NUMBER
1	1 Gallon (3.8L) Grinding Oil	000-2112-73
2	7" General Purpose Grinding Wheel	010-0709-00
3	3" General Purpose Stem Grinding Wheel	010-0300-72
4	Chuck Assembly/Disassembly Tool	012-1054-60
5	Spanner Wrench	025-0150-02
6	Protective Chuck Cover	012-1050-12
7	Valve Stop Rod Tool	012-1025-00
8	Diamond Dressing Tool – Tip Grinding	024-0131-11
9	Diamond Dressing Tool – Face Grinding	023-0129-44
10	Rocker Arm Attachment Assembly	012-1120-00
11	Grinding Oil Splash Guard	012-1208-00

## SET-UP AND INSTALLATION INSTRUCTIONS

After uncrating, check for hidden damage. If any is found, contact your carrier immediately.

1. Place your valve facer in its pre-determined location and carefully remove crating.
2. Remove all rust preventative with a clean cloth and appropriate solvent such as denatured alcohol or equivalent. **Do not use any cleaner or lubricant in the chuck balls area except Automatic Transmission Fluid (ATF).**
3. Be sure Grinding Oil reservoir is free of all packing materials.
4. Remove the 1/4-20 hex head cap screw from the swivel plate (located next to the chuck swivel plate clamp on the front of the machine).
5. Remove the "U" bracket from the spindle slide stop by loosening the cap nut and right most thumb screw. Then rock the bracket bottom toward you and away from the slide bar. Then re-tighten the cap nut and thumb screw.
6. Check electrical voltage input tag on the valve facer to be sure it matches your service.

**CAUTION: Be certain that the machine is properly grounded.**

7. Check grinding oil drain plugs and if tight, fill the sump until the fluid level is approximately 25mm above the baffle rib.
8. Connect a filtered and lubricated air supply (65 PSI / 4.5 BAR Min.) to the air inlet at the rear of the machine after attaching your shops' style of air supply fitting.

## SETTING THE SWIVEL PLATE ANGLE

The swivel plate is marked in 1° increments from 13° to 62°. Actual setting for 15°, 30° and 45° are indicated with these numbers.

To set the angle:

1. Loosen the Locking Handle (Item 1, Figure 1) and set the edge of the swivel plate to the desired angle.
2. Tighten the Locking Handle (clockwise).

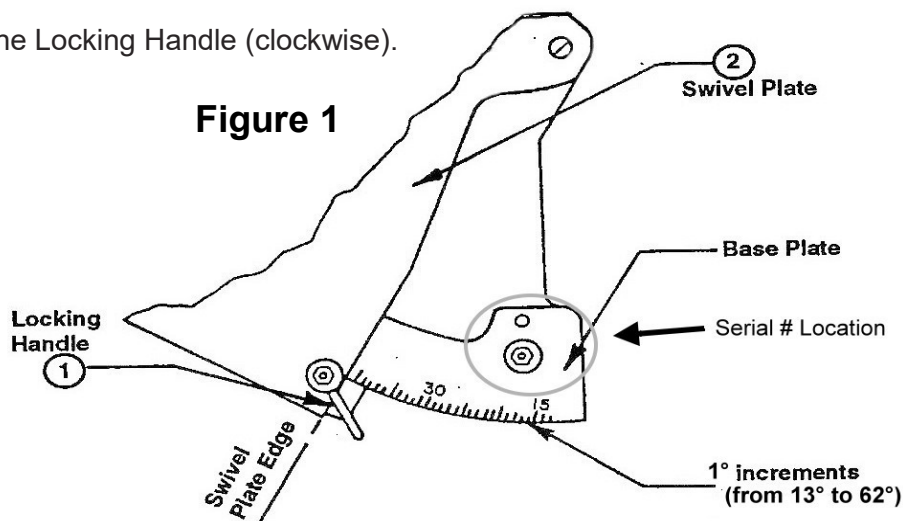

## SETTING THE CHUCK VALVE STOP

The valve stop is a device designed to locate all like valves at a given relative distance from the end of the chuck.

To set the valve stop:

1. Install a valve in the chuck at the desired depth and allow the chuck to close.
2. Using the 3/16" diameter valve stop rod provided, push the valve stop in until it is seated against the valve stem end.

**NOTE:** Be sure subsequent valves are pushed in far enough to contact the stop.

## SETTING SPINDLE SLIDE STOPS

This machine is equipped with adjustable stops to limit the travel of the grinding wheel spindle slide. These stops, when set, prevent the wheel from striking the chuck or the valve stem.

1. With the valve installed in the chuck, all motors off, and the thumbscrews loose, advance the traverse handle to the left.
2. Feed valve up to valve wheel.
3. Be sure the grinding wheel does not strike either the chuck or the valve stem.
4. Slide the right hand adjustable stop up against the fixed stop and tighten thumb screw.

## CONTROLS AND SWITCHES

Before attempting to operate this machine, first familiarize yourself with all controls and switches and the functions of each.

### MAIN SWITCH (Item 1, Figure 2 below)

This switch has three positions. In the left position, both the spindle and the chuck motor are on. With the switch in the right position, only the spindle motor will run. When centered, both chuck and spindle motors are off.

Figure 2

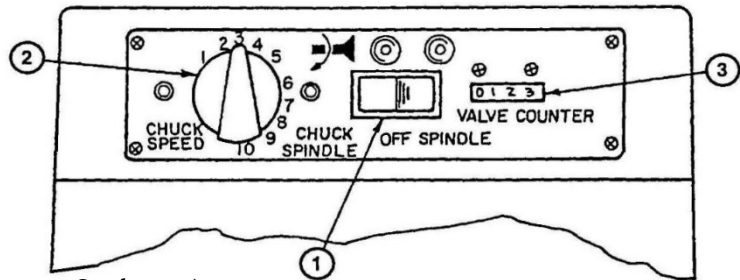

### CHUCK SPEED CONTROLLERS (Item 2, Figure 2 above)

Your SVSII Deluxe Valve Facer is equipped with a variable speed chuck motor, which allows you to alter the rotational speed based on the valve head diameter (See chart on chuck cover).

### SPINDLE SLIDE SWITCH

This machine is equipped with an automatic switch, which shuts off the spindle (grinding) motor, chuck motor and the grinding oil pump when the traverse handle (Item 3, Figure 4) is in the far right position.

### VALVE COUNTER (Item 3, Figure 2)

This machine is equipped with an automatic valve counter enabling you to keep an accurate count of valve facing production.

**EMERGENCY STOP (Figure 3, Item 1)**

- Push down to stop the machine.
- Pull up to reset back to normal operating mode.

Fast easy access to the “All Stop” condition in case of a need to stop the machine immediately.

**POWER LOSS RESET BUTTON (Figure 3, Item 2)**

- Push to reset (may need to momentary hold)

If the power is lost the power loss reset button needs to be pushed in order for the machine to turn on.

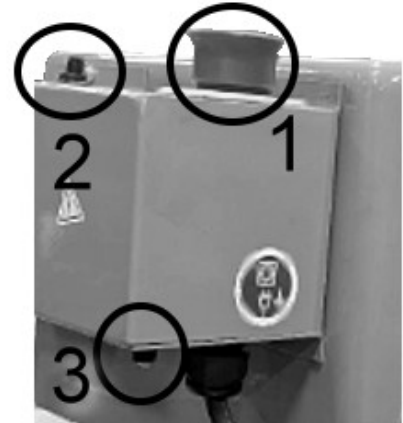

Figure 3

**ATTENTION:**

Any time this machine is removed from power (unplugged) it will not function until the **POWER LOSS RESET BUTTON** is pressed to re-engage the power system.

**CIRCUIT BREAKER RESET BUTTON (Figure 3, Item 3)**

- Push to reset

In the event of a power overload, power surge, or a wiring short, this will stop power to the machine. When that happens this button will need to be pressed to reset the breaker.



## MOUNTING THE VALVE AND STEM GRINDING WHEELS



How-To Video

**WARNING:** Always disconnect the machine from the power source before attempting to change wheels.

The valve and stem grinding wheels are attached with special spanner nuts and a spanner wrench (PN: 025-0150-02) for its removal is included with the accessories.

**Figure 3**

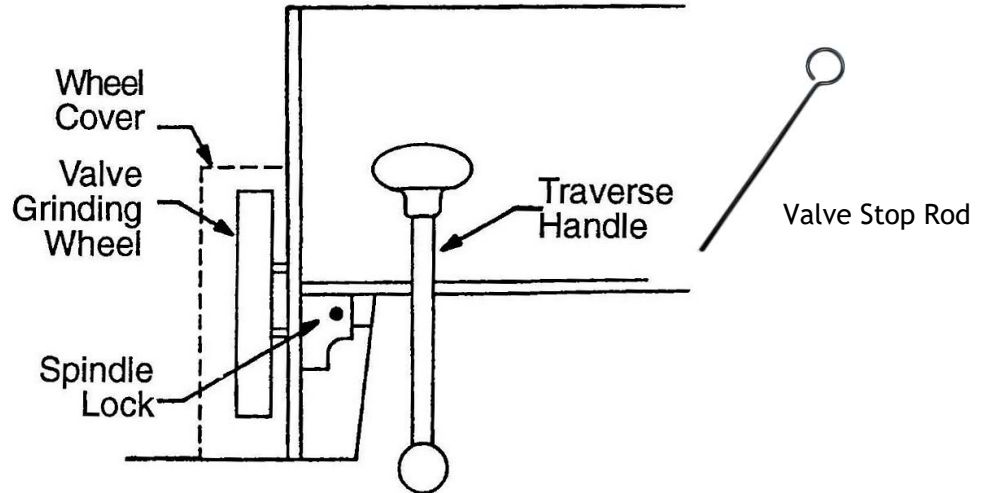

### VALVE GRINDING WHEEL REMOVAL & INSTALLATION

1. Remove the three mounting screws holding the wheel guard in place.
2. Insert the 3/16" diameter valve stop rod provided. (This will keep the spindle from turning while removing the grinding wheel nut.)
3. With the special spanner wrench (PN: 025-0150-02), remove the grinding wheel nut (Right Hand Threads) and then the grinding wheel.
4. Make certain the grinding wheel nut (PN: 012-1004-00) is tight.
5. Install the new grinding wheel and grinding wheel nut, then tighten.
6. Remove special pin and re-install wheel guard.

### STEM GRINDING WHEEL REMOVAL & INSTALLATION

1. It is not necessary to remove the wheel guard to remove this wheel!
2. Insert the 3/16" diameter Valve Stop Rod provided. (This will keep the spindle from turning) See Figure 3.
3. With the special spanner wrench (PN: 025-0150-02), remove the cut-off wheel nut (**Left Hand Threads**) and then the grinding wheel.
4. Install the new grinding wheel and cut-off wheel nut, then tighten.
5. Remove the Valve Stop Rod.



1. Main Switch	11. Micro Feed Dial
2. Grinding Oil Control Valves*	12. Spindle Slide Adjustable Stops*
3. Traverse Handle	13. Valve Stop Screw*
4. Valve Feed Hand wheel	14. Chuck Cover
5. Chuck Open-Close Button	15. Chuck Speed Dial
6. Rocker Arm Grinding Assembly*	16. Valve Counter
7. Surface Grinding Assembly	17. Emergency Stop Button
8. Swivel Plate Lock	18. Reset after Power Outage
9. Chuck Hand wheel	19. Overload Reset Button
10. Surface Grinding Micro Feed Wheel	20. Light Switch

\*NOTE: These items are not visible in this view of machine

**Figure 4**

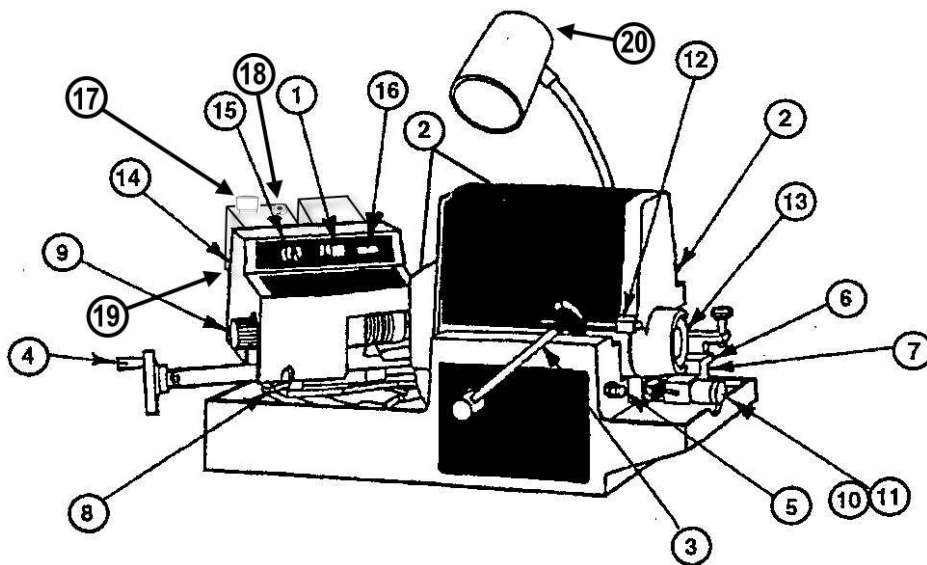

## DRESSING THE WHEEL

NOTE: See "Trouble Shooting Guide" for tips on properly dressing the wheel.

As the wheel is used, particles break away from the face of the wheel. This requires that the wheel face be dressed. The process of dressing the grinding wheel face returns its condition to a smooth and flat surface for the best possible finish on the face of the valve.

**NOTE:** A new wheel (or re-installed one which has been off the machine) must be dressed prior to use.

**WARNING: Never dress the wheel without first covering the chuck.**  
(Use the included protective chuck cover. 012-1050-12)

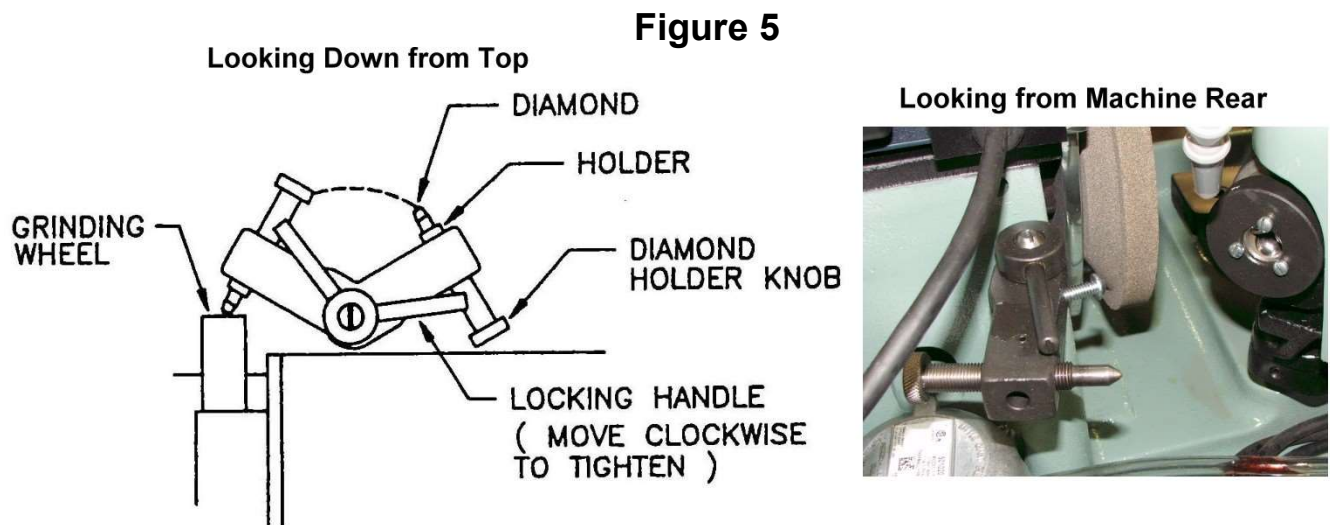

1. Turn the main switch to the OFF (center) position.
2. Loosen the lock arm and swing the diamond toward the left.
3. Using the traverse handle, locate the grinding wheel so that the diamond point just contacts the center of the face and lock in place.
4. Position the wheel to the left of the diamond.
5. Depress the right side of the main switch turning on the spindle and grinding oil pump.

**NOTE: Grinding wheel must always be directed onto the diamond when dressing.**

6. Using a very slow uniform motion, move the grinding wheel across the diamond.

**NOTE: Primary cut must always be into the point of the diamond.**

7. Return the wheel to the left and adjust the diamond about 1/8 turn clockwise.
8. Make an additional, very slow pass with the wheel (left to right, right to left) and turn the spindle motor off.



[Stem Grinding Video](#)

## PRECAUTIONS WHEN DRESSING THE WHEEL

1. Take very light cuts, heavy cuts may grind away the mounting and loosen the diamond.
2. Avoid shocks or blows to the diamond tool.
3. The diamond and tool must be locked firmly and the wheel fed gradually across the diamond point.
4. Be careful not to jam the wheel into the diamond.

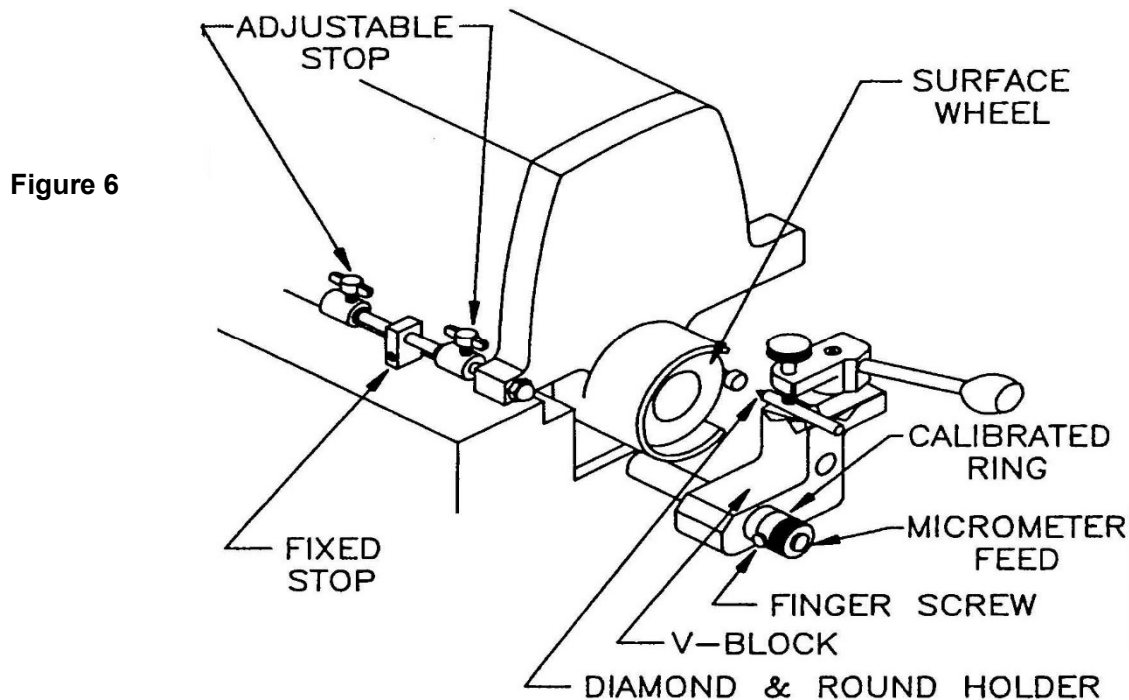

## DRESSING THE STEM WHEEL (SEE FIGURE 6)

The stem wheel needs to be dressed periodically to maintain a sharp cutting edge and clean face.

1. Depress the right side of the rocker switch (spindle) and move the traverse handle to the left until the spindle motor comes on.
2. Leave the spindle slide in this location and turn the motor off (center position on the main switch).
3. Loosen the adjustable spindle slide stop, move it up tight against the fixed stop and tighten it to prevent the spindle slide from moving while dressing the stem wheel.
4. Install the round diamond in the V-block and clamp it in place.
5. Using the micrometer feed, move the diamond point in until it just touches the stem wheel.
6. Move the diamond clear of the wheel and turn the main switch to the spindle "ON" position.

**NOTE: Grinding oil must always be directed onto the diamond when dressing.**

7. Sweep the diamond across the face of the wheel feeding in .003 to .005 until the face has been totally cleaned up.

## VALVE FACING

De-grease/clean valves, making sure they are free of carbon deposits BEFORE attempting to grind.

### PRE-GRIND SET UP

1. Dress the grinding wheel (as needed).
2. Install the valve in the chuck and use the Valve Stop Rod to set the valve stop inside the Chuck.
3. Set the swivel plate to the desired angle.
4. Set the spindle slide stop.
5. Set the chuck speed as dictated by the valve head diameter.



Dressing the  
Grinding Wheel  
Video

### FACING THE VALVE

1. With the traverse handle in the extreme right hand position, depress the left side (chuck/spindle) of the rocker switch, turning on the power to the machine.
2. Move the traverse handle slowly to the left until the motors and grinding oil pump comes on.

**NOTE: Adjust the grinding oil flow onto the face of the valve. Never allow the grinding oil to be directed into the chuck. Suspended grit in the oil will cause damage to the chuck balls and collars.**

3. Bring the valve face into contact with the grinding wheel by SLOWLY turning the feed hand wheel clockwise while at the same time slowly passing the wheel back and forth.
4. As the last low spot is removed, stop feeding the hand wheel in and pass the wheel across the face 3 or 4 times. (This will put on the finish grind). Allow the valve to spark out before proceeding to step 5.
5. Park the wheel in contact with the valve and turn the hand wheel counter-clockwise moving the valve face away from the grinding machine.

**WARNING: DO NOT draw the wheel off the valve.**

6. Move the traverse handle to the extreme right so the automatic switch shuts off both motors.

**WARNING: NEVER attempt to release or remove the valve from the chuck while either motor is still turning.**

7. Press the chuck release valve and remove the finished valve.

## CUT-OFF GRINDING (FIGURE 7)

1. Depress the toggle switch to the right side position and move the grinder spindle slide to the left until the spindle motor comes on. Leave the slide in this position and shut the motor off at the toggle switch.
2. Lock the grinder spindle slide in this position by moving the two adjustable stops to contact the fixed stop.
3. Place the valve on the V-block, bringing it over the face of the wheel, and lock down in the V-block with the stem tip just contacting the wheel. Turn the motor on and take a light cut across the end of the valve stem.

**Figure 7**

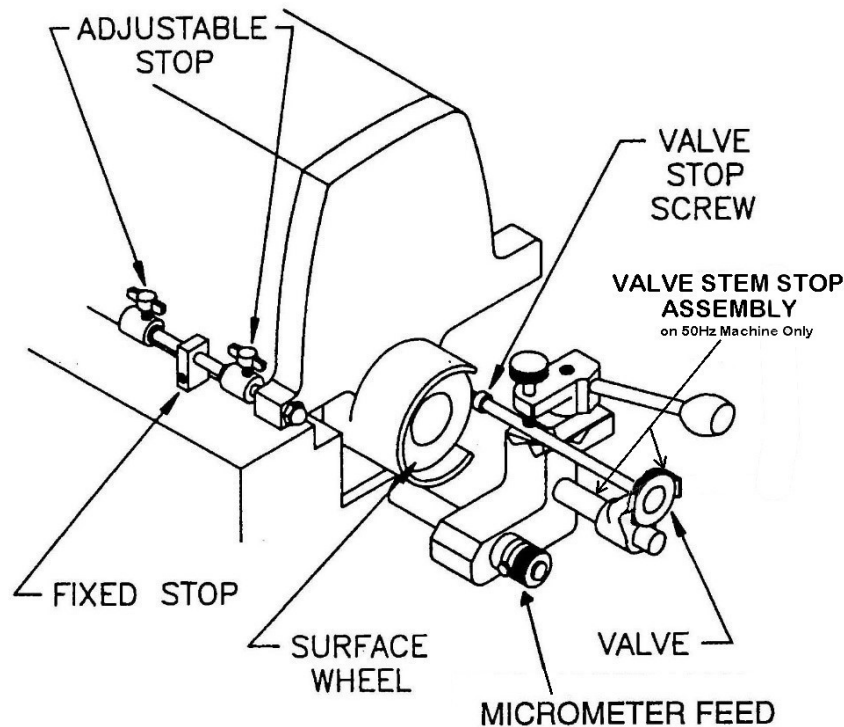

Stem Grinding Video

Before removing the valve, move the V-block back to the rest position and adjust the valve stop screw and jam nut until it contacts the end of the valve stem. This sets the stop screw even with the front edge of the wheel and all other valve stems can be set in the V-blocks against the stop.

4. Set calibration ring to zero, rotate the V-block holder so that the valve stem end is between the stop screw and the wheel edge.
5. Feed the valve stem up by rotating the feed wheel the amount of stock that is to be ground off. (Should not exceed 0.002 inch (0.051mm) per pass).

**NOTE:** This Cut-Off Grinding should be performed using grinding oil directed over the Stem Wheel.

**WARNING:** Never attempt to remove the valve from the V-block while the grinding wheel is still turning.

## VARYING WHEEL PERFORMANCE

It is possible to alter the performance of a grinding wheel by varying the traverse speed, infeed (amount of material being removed) or the speed of work. If a wheel acts as though it is too hard (causing burning, chatter, slow cutting or loading) it can be made to act softer by:

1. Increasing the work speed,
2. Increasing the traverse speed,
3. Increasing the infeed,
4. Dressing at a faster traverse speed, or
5. Dressing more often.

If a wheel acts as though it is too soft (not holding size or requiring excessive dressing), it can be made to act harder by:

1. Decreasing the work speed,
2. Decreasing the traverse speed,
3. Decreasing the infeed, or
4. Dressing at a slower traverse speed.

Use the correct Kwik-Way brand grinding stone to match the material being ground. If you are grinding titanium valves then you should use a stone designed for use on titanium. Irontite Products uses the same formulation on the stones we offer as Kwik-Way has always used. The combination of our specially formulated stones, grinding oil, and the precision of our exclusive chuck design means you will get the best possible finish. Using other products can affect the quality of finish and the life of the stone.

010-0710-08	7" Finishing Grinding Wheel
010-0709-00	7" General Purpose Grinding Wheel
010-0708-05	7" Titanium Grinding Wheel
010-0707-50	7" Stellite Grinding Wheel
010-0300-72	3" General Purpose Grinding Wheel
010-0300-13	3" Finishing Grinding Wheel

It's very important to keep your Chuck free of debris. Disassemble and clean your chuck should you encounter any problem with its operation or excessive runout. (See Chuck disassembly section in this manual)

Use Kwik-Way grinding oil (000-2112-73 gal.) and keep your grinding oil free of contaminants to get the best possible performance. Kwik-Way brand grinding oil is specifically formulated to work with Kwik-Way brand grinding stones.

This is because the oil is designed to optimize the performance of Kwik-Way stones, ensuring efficient grinding, a smooth finish, and extended stone life.

### *Tech-Tip*

Keyser Mirror Finish (PN: 000-2111-66) – Keyser Mirror Finish valve grinding aid is specially formulated for Titanium, Stainless, Stellite and other valves. It eliminates chatter and wheel loading, provides exceptional surface quality, and increases stone life.

## ROCKER ARM GRINDING

It is not necessary to remove the stem grinding attachment to grind rocker arms. Rotate the stem attachment from its at-rest position toward the front of the machine.

### SET-UP

1. Move the traverse handle to the extreme right and depress the spindle switch.
2. Slowly move the traverse handle to the left until the spindle motor starts.
3. Allow the traverse handle to remain in this position and turn the spindle motor off.
4. Loosen the stops, slide them against the fixed stop and lock in place.
5. Mount the rocker arm between the cones (See Figure 9) and position the attachment so that the wheel is in contact with the grinding wheel (See Figure 10).

**Figure 8**

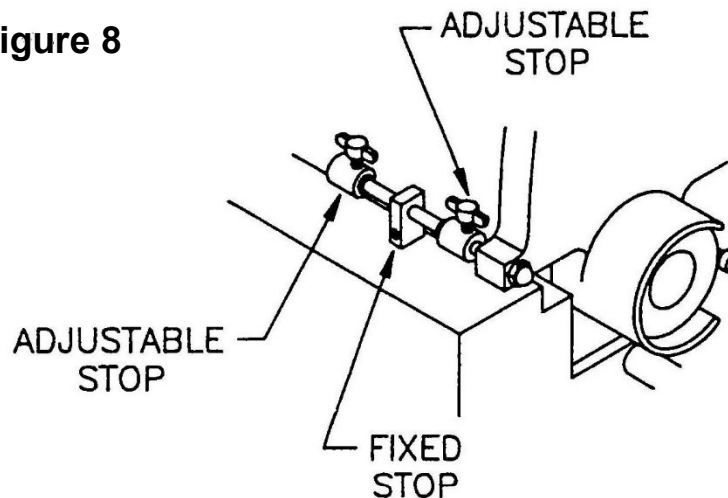

**Figure 9**

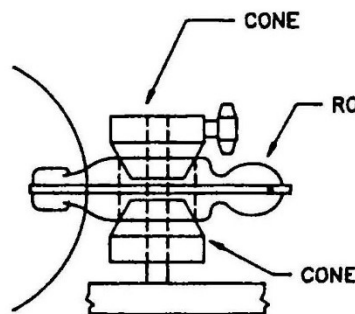

**Figure 10**

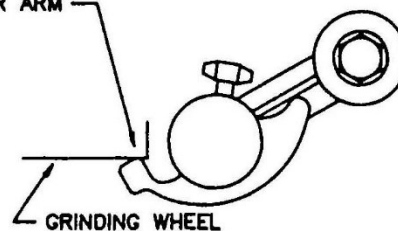

## ROCKER ARM GRINDING PROCEDURE

Start the spindle motor and direct the grinding oil flow onto the rocker arm shoe.

1. Apply light pressure and slowly rotate the face of the shoe back and forth across the grinding wheel.

**IMPORTANT:** Be sure that the rocker arm shoe is in continuous contact with the wheel during complete travel in both directions.

2. Continue grinding until the entire shoe surface is cleaned up.

**CAUTION: DO NOT** stop rocker arm movement while shoe is in contact with the grinding wheel. If rocker arm is allowed to dwell in one location, a flat spot will occur.

3. Turn off the spindle motor and remove the finished rocker arm.

**WARNING: DO NOT** attempt to remove the rocker arm while the grinding wheel is still turning.

4. When the rocker arm grinding process has been completed, return both this attachment and the V-block to their original locations.

## MOTOR/BELT INSTALLATION

When installing a motor or belts, the center line (CL) motor must be parallel to the top of the spindle slide. (See Figure 11)

Failure to accurately install/adjust the motor will cause premature belt breakage.

**Poly Belts stretch to fit.** Always replace both belts, never just one. (000-2303-62, quantity 2 required)

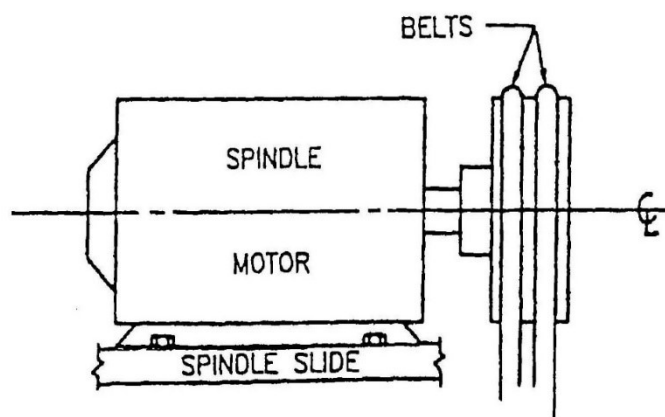

**Figure 11**

## **SPINDLE SLIDE ADJUSTMENT**

**(For Serial No. 4315 and up)**

If the spindle slide should need adjustment, start by locating the three socket head set screws at the rear of the machine just below the slide (See Figure 12).

**WARNING:** Disconnect the machine from its power source BEFORE beginning any adjustments.

1. Position the traverse handle in the vertical position.

**NOTE:** All screw adjustments are to begin with the handle in this position.

2. The first adjustment will be to the setscrew nearest the large diameter-grinding wheel. Tighten this screw until the spindle slide cannot be moved when using the traverse handle.
3. SLOWLY loosen this screw while attempting to move the traverse handle - stop loosening the screw when the traverse handle can be cycled through its entire range and a noticeable amount of smooth drag is achieved.

**Figure 12**

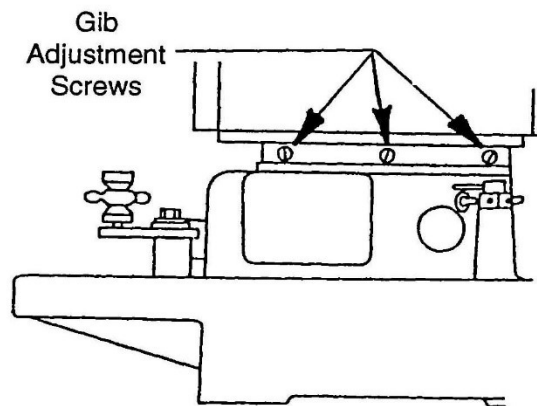

1. The next adjustment is to the screw nearest the small diameter-grinding wheel. Tighten this screw until once again the spindle slide cannot be moved with the traverse handle.
2. SLOWLY loosen this setscrew while rocking the traverse handle back and forth - stop when the slide moves smooth and free, yet drag can be detected.
3. While standing on the operator side, grasp both the large diameter and small diameter grinding wheel covers and alternatively push/pull on each, checking for any movement of the spindle slide. If no movement is detected, go to Step 7. If MOVEMENT IS DETECTED, one of the Gib screws is too loose and will cause inaccuracy - repeat Steps 2 through 6.
4. Tighten the screw in the center until the spindle slide cannot be moved - SLOWLY loosen this screw while rocking the traverse handle side to side. Continue to loosen the screw, stopping when the amount of drag felt in the center matches that provided by the outer screws.

## CHUCK SLIDE

The chuck slide uses spring loaded gib screws, which **can be damaged** if they are over tightened. Carefully tighten each spring loaded gib screw until it bottoms out and then back it off 1/2 turn (See Figure 13).

**Figure 13**

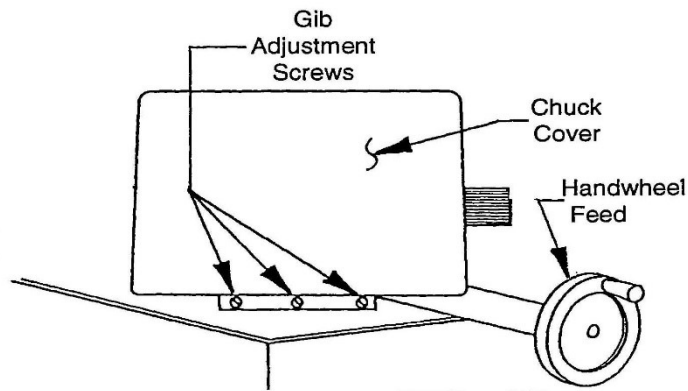

## MICRO SWITCH ADJUSTMENT

(See Figure 14)

The micro switch (Item 1) when properly adjusted, will shut off the chuck motor before the chuck yoke pin (Item 3) engages the chuck flange (Item 4). This switch is a safety device to prevent stripping the gears in the chuck motor.

1. Disconnect the machine from the power source and air supply and remove the chuck cover.
2. Move the chuck yoke (Item 2) by hand (you should hear a click in the micro switch before feeling the chuck yoke pin - Item 3) and engage the chuck flange (Item 4).
3. If the chuck yoke pin engages the chuck flange first, adjust the switch bracket by bending away from the chuck yoke slightly, re-check per Step 2.
4. Reattach chuck cover.

**Figure 14**

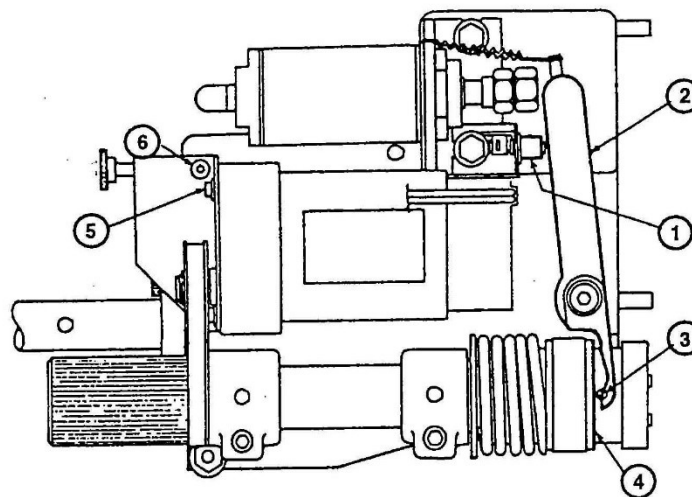

## CHUCK DRIVE BELT ADJUSTMENT

(See Figure Below)

Proper adjustment of the chuck drive belt (001-1899-90) will insure long life.

It is not necessary to run excessive tension with this belt. (Positive drive belts require less tension than "V" type belts). Belt tension is adjusted by the motor mount bolts (Item 5 below). If the belt runs to one side then the motor shaft is not parallel to the chuck. This is adjusted by bracket bolts (Item 3, below). Loosen and adjust the motor until the belt runs true. Re-tighten bolts. It may be necessary to re-adjust belt tension. Once complete, the belt should provide long life and trouble free operation.

**CAUTION: When adjusting belt tension, DO NOT over tighten, belt should just tight enough to not slip on the pulley.**

**NOTE:** Chuck shaft must rotate freely, by hand. Over tightening bearing cap screws will damage the gear motor. These should be snug. They are not intended to stop lateral movement of the chuck. Lateral movement is prevented by the position of the belt pulley on the end of the chuck being tight up against the chuck mount bearing mount.

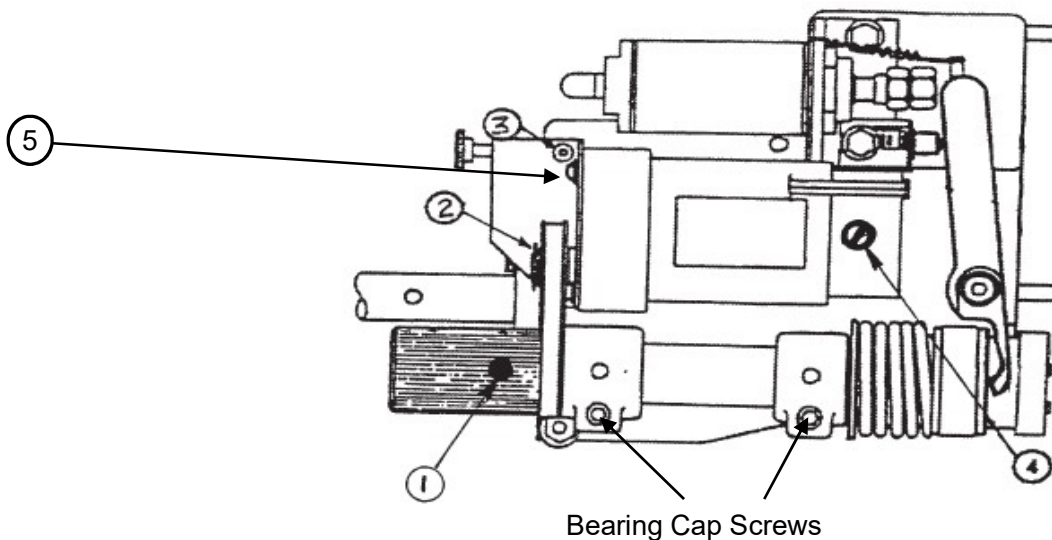

## PROPER BEARING CAP SCREW ADJUSTMENT

Start with the bearing cap screw closest to the Valve end of the chuck. While rotating the chuck with your left hand, tighten the bearing cap screw until you feel resistance turning and very slightly back off the screw. Then move to the other bearing cap screw and repeat the process. Finally go back to the first bearing cap screw and repeat the process. The last step is to check to see if there is any lateral play. If there is lateral play loosen the splined pulley set screw (number 1 above) and while pushing the valve end of the chuck back with your right hand, slide the splined pulley up on the chuck shaft until it just barely touches the Bearing Saddle and then tighten the set screw. You want no lateral movement of the chuck, but you also do not want the pulley to be creating any drag by rubbing against the bearing saddle.

## CHUCK ASSEMBLY REMOVAL

If it is necessary to remove the complete chuck assembly for replacement, proceed as follows:

1. Remove the chuck cover.
2. Remove the chuck yoke pivot cap screw. Disconnect return spring and move the chuck yoke out of the way.
3. Loosen the four socket head cap screws mounting the motor to the motor bracket to relieve the belt tension.
4. Loosen the set screw in the chuck shaft pulley/hand wheel and remove the chuck shaft assembly.

**a. To re-install a chuck shaft, reverse steps 1 through 4.**

1. Make certain that the shoulder on the valve head end of the chuck is back snug against the solid bearing.
2. When installing the pulley/hand wheel, make certain it is drawn up snug yet the chuck shaft can turn freely. Then tighten the setscrew.

**NOTE:** When replacing the chuck assembly, remove the Valve Stop from inside the chuck shaft by pushing it out the back of the chuck after removing the spline pulley.



**Valve Stop  
(PN: 013-0370-19)**

### *Stay Updated with [kwik-way.com](http://kwik-way.com)*

For the latest information and support on your machine, visit [kwik-way.com](http://kwik-way.com).

- **Free Manual Downloads:** Find the most recent version of this manual.
- **Replacement Parts:** View photos, descriptions, and pricing for common replacement parts.
  - **International Customers:** Contact International Sales at +1 319-377-9421 or [international@kwik-way.com](mailto:international@kwik-way.com).
- **Helpful Resources:** Access videos and blog articles for tips, troubleshooting, and best practices.

## CLEANING THE CHUCK (CHUCK DISASSEMBLY)



**WARNING:** Disconnect the machine from its power source before cleaning the chuck.

The Valve Chuck Disassembly / Assembly Tool is required to perform the following procedures safely.









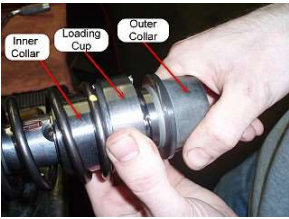

Chuck Disassembly Video

Carefully clean all chuck parts using denatured alcohol and only use Automatic Transmission Fluid to lubricate the chuck components.

	<p>1) Remove the chuck cover from the Chuck Bearing Assembly, being careful not to pull any wires from the cover. Rotate the Chuck so that the Grind Mark on the front collar and the Yellow Mark on the Spring are Vertical as show in the photo left.</p>	<p>2) Remove the (3) three 8 x 32 x 5/16 slot head screws from the Chuck End Cap (Black) shown right.</p>	
	<p>3) Use the Disassembly Tool (picture at the top) that comes with your machine, put the 8 x 32 screws (3) into the chuck shaft in a 1/4 of an inch. Put the 1/4 x 20 Hex Head Bolt finger tight against the End Plate.</p>	<p>4) Remove the Chuck Yoke</p>	
	<p>5) Loosen the 1/4 x 20 Hex head bolt counter clockwise. As you release the 1/4 x 20 bolt, the spring pressure should begin to release.. NOTE: You may need to soak the chuck in Automatic Transmission Fluid to remove grit and make the collars slide easier.</p>	<p>6) Remove the Chuck Disassembly Tool.</p>	
	<p>7) Begin to remove the outer collar from the chuck shaft. Next, remove the Loading Cup with the Four (4) springs. The large spring and inner collar will be removed along with the Thrust Step Washer. As you take the Inner collar off the steel chuck balls (9/16) may fall out of the chuck shaft.</p>	<p>8) Remove the Chuck Hand wheel and belt from the chuck shaft. Remove the chuck from the chuck bearing assembly. Clean all parts with a parts cleaning solvent.</p>	

## ASSEMBLY INSTRUCTIONS

	<p>9) Put the shaft back in the chuck bearing slide, use automatic transmission fluid <b>only</b> and coat the chuck shaft.</p> <p>Make sure the keys are vertical.</p>	<p>10) Put the thrust washer, spring, and (3) three rear balls back on the chuck shaft, making sure that the Yellow mark is lined up with the Keys. Hold on to the bottom balls so they don't fall out of the shaft</p>	
	<p>11) Slide on the Inner collar, so all three rear balls are inside of the collar.</p>	<p>12) Put the front set of balls in the shaft. Install the loading cup with four (4) springs facing out.</p>	
	<p>13) Install the outer collar, making sure the grind mark is lined up with the keyways.</p>	<p>14) Reinstall the Disassembly tool. Put the three screws (8 x 32) in one quarter (1/4) of an inch. Begin to tighten the 1/4 x 20 bolt, making sure that the collars are still lined up with the keys. Run 1/4 x 20 bolt in until it is tight.</p>	
	<p>15) Reinstall the Chuck Yoke.</p>	<p>16) Remove the Disassembly Tool and reinstall the chuck End Cap with the three 8 x 32 screws.</p>	
	<p>17) Reinstall the chuck Hand wheel and Belt, making sure the chuck and chuck hand wheel are snug to the chuck bearing slide.</p>	<p>18) Reinstall the chuck cover. Make sure there are no wires touching the chuck.</p>	

## HELPFUL HINTS

1. **GET ACQUAINTED WITH YOUR KWIK-WAY VALVE FACER.** We recommend that you use scrap valves and practice before beginning an actual job. This will avoid any undue pressure or failure while learning a new procedure.
2. **ALWAYS** cover the chuck before dressing the valve grinding wheel using the provided chuck cover (012-1050-12) or at least a shop towel.
3. **ALWAYS** dress a grinding wheel after installation (whether new or reinstalling).
4. If the grinding wheel becomes impregnated with grease or lubricating oil, remove the spindle, soak in solvent overnight, reinstall and turn the motor on. This will throw out the oil by centrifugal force.
5. **ALWAYS** use Kwik-Way Grinding Oil (PN: 000-2112-73) when dressing the grinding wheel.
6. A good grinding practice is to take very light cuts and slowly pass the wheel back and forth across the valve face many times.
7. **ALWAYS** clean and degrease valves before grinding to prevent the grinding wheel from “loading up” with residue.
8. For best valve face finish, dress the grinding wheel to a “glassy smooth” surface.
9. **Keep debris and residue from getting in the chuck ball and collar area.** Only use Automatic Transmission Fluid (ATF) to lubricate this area of the chuck. Never use a penetrating oil or spray like WD-40. These will leave a residue and affect the chuck accuracy.
10. If you notice excessive runout of your chuck you should disassemble it per the instructions in this manual cleaning all parts with denatured alcohol and reassemble using ATF for lubrication.

### *Stay Updated with kwik-way.com*

For the latest information and support on your machine, visit [kwik-way.com](http://kwik-way.com).

- **Free Manual Downloads:** Find the most recent version of this manual.
- **Replacement Parts:** View photos, descriptions, and pricing for common replacement parts.
  - **International Customers:** Contact International Sales at +1 319-377-9421 or [international@kwik-way.com](mailto:international@kwik-way.com).
- **Helpful Resources:** Access videos and blog articles for tips, troubleshooting, and best practices.

## MAINTENANCE

Your **KWIK-WAY SVS II Deluxe** Valve Facing Machine is designed as a minimal maintenance product. However, some basic maintenance will assure that it will continue to operate in a satisfactory manner.

### LUBRICATION

1. Grinder spindle slide ways are equipped with snap-lid oilers (1 front, 1 rear) and must be oiled with 30 wt. motor oil once a week (more frequently if machine is in continuous service).
2. Chuck slide feed screw is equipped with a snap-lid oiler located near the hand wheel.
3. Gib and dovetail ways have two (2) snap-lid oilers, one behind the chuck motor and the other under the chuck shaft and between the chuck bearings.
4. The crankshaft assembly, chuck motor and gear case are all lubricated for life and require no additional lubrication.
5. Stem grinding attachment requires only a few drops of oil placed on either side of the V-block on a weekly basis.

**The Chuck Collar Area** - This area *should only be lubricated with Automatic Transmission Fluid.* Use a spray bottle and use sparingly. If you notice the chuck opening and closing slowly or in a sticky motion use **a little ATF spray** and actuate the open and close switch several times to spread the lubrication. **DO NOT USE WD-40 or any other SPRAY LUBRICANTS or PENETRATING OILS. NO BRAKE OR CARBURETOR CLEANER EITHER!**

**Valve Slide Feed Hand Wheel Adjustment** – If the valve slide has too much play, adjust it by turning the hand wheel so the set screw is visible, then turn it one full rotation clockwise, loosen the set screw and push inward on the hand wheel then tighten the set screw.

Grinding Oil should be changed as needed when it gets dirty. Use only Kwik-Way Grinding Oil P/N: 000-2112-73 and Kwik-Way formula grinding stones for best results. Use of other Grinding Oil will significantly affect the performance of the machine and **VOID THE WARRANTY.**

Always cover the chuck with the provided chuck cover or a shop towel when dressing your grinding stone to keep debris from entering the chuck collar area. **Never direct your grinding oil nozzle into or over the chuck as this can introduce debris into your chuck and cause it to wear prematurely.**

### REPLACING THE DRESSER DIAMOND

Before removing the old dresser diamond you must tighten down the set screw on the diamond dresser holder. This holds the brass pointed tensioner in place back away from the diamond threads while changing out the diamond. Failure to do this step will make it impossible to screw in the new diamond holder. And could damage the new diamond or the brass pointed tensioner.

(See page 50 for more information)

# SPINDLE ASSEMBLY DRAWING 220V/50HZ

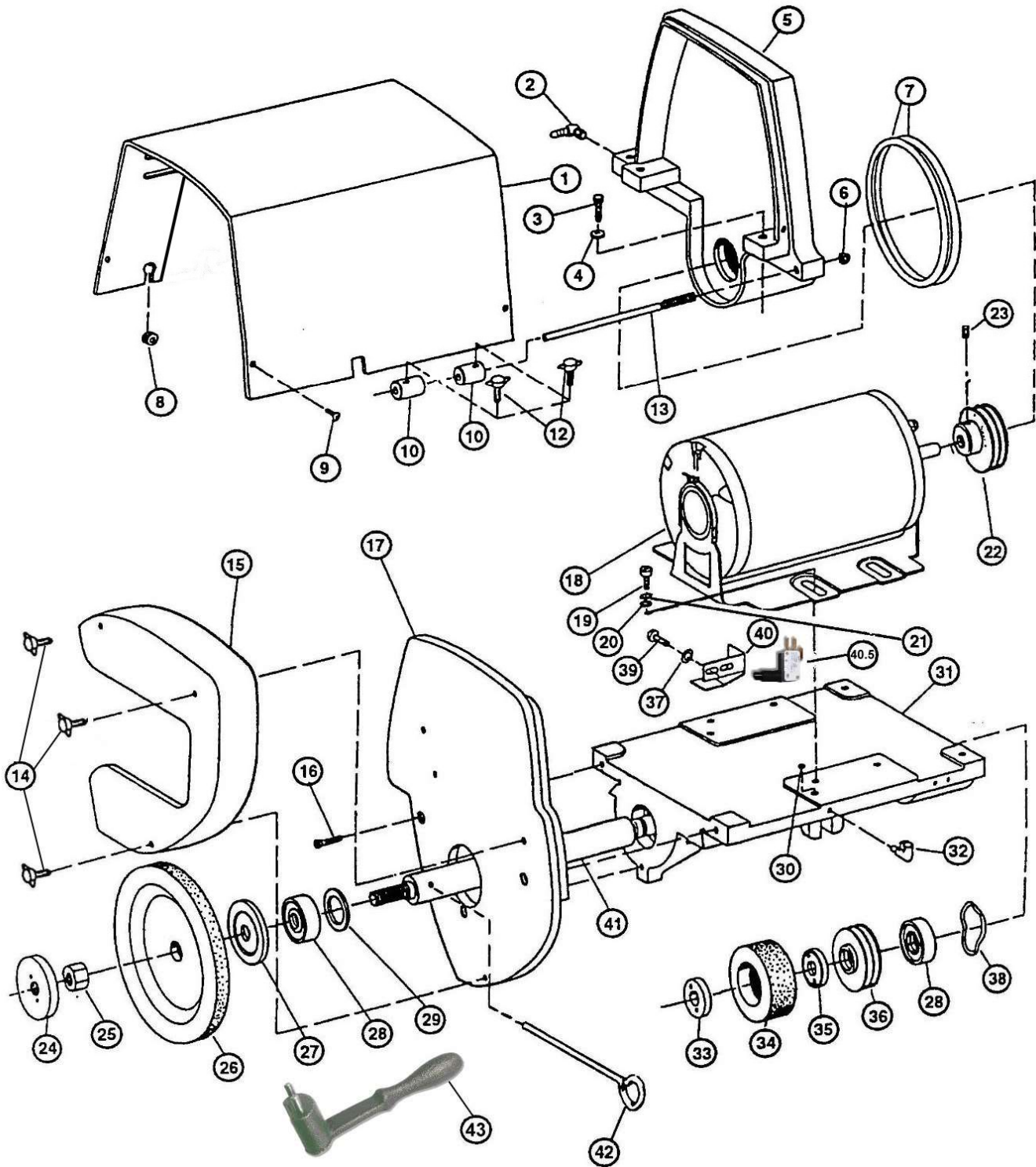

## SPINDLE ASSEMBLY DRAWING 220V/50HZ

Item	Part Number	Description	Quantity
1.	012-0020-10	Spindle Motor Cover	1
2.	000-1567-95	90° Elbow 1/4 x 1/8 MPT	1
3.	000-0168-02	5/16-18 x 1 Soc. Hd. C.S.	2
4.	000-1145-02	1/4 Iron Washer	2
5.	012-3007-10	Motor Sheave Guard	1
6.	000-0150-08	5/16-18 Hex Cap Nut	1
7.	000-2303-62	O-Ring Belt – 50 & 60 Hz	2
8.	000-2700-24	3/8 ID Grommet	1
9.	000-0595-01	10-24 x 3/8 Button Hd. C.S.	4
10.	012-1092-20	Stop Collar	2
11.		{removed}	
12.	060-1125-00	T-Bolt Thumbscrew Assembly	2
13.	012-1092-30	Stop Rod	1
14.	012-0012-06	Wheel Guard T-Bolt, Assembly	3
15.	012-0012-07	Wheel Guard Cover	1
16.	000-0123-47	1/4-20 x 3/4 Flat Hd. Soc. C.S.	3
17.	012-0036-00	Wheel Guard Plate	1
18.	001-1949-24	Motor 115/230-60/50-1 phase	1
19.	000-0165-19	1/4-20 x 1/2 Soc. Hd. C.S	4
20.	000-1155-25	1/4 SAE Washer	4
21.	000-1170-48	1/4 Int. Lock washer	4
22.	012-1000-30	Motor Sheave 50Hz	1
23.	000-0485-24	1/4-20 x 3/8 Nylon Soc. Cup S.S	1
24.	012-1004-00	Grinding Wheel Nut	1
25.	012-1003-00	Grinding Wheel Bushing	1
26.	010-0709-00	Grinding Wheel, General Purpose	1
27.	012-1005-07	Grinding Wheel Flange	1
28.	000-1605-12	Bearing	2
29.	000-2003-44	Gasket	1
30.	023-0201-90	Plug	1
31.	012-3004-00	Spindle Bearing Slide	2
32.	000-1900-20	1/4 Angle Oiler	1
33.	024-0646-03	Cut-off Grinding Wheel Nut	2
34.	010-0300-72	Cut-off Wheel	1
35.	013-0218-05	Spindle Pulley Nut	1
36.	012-1001-20	Spindle Sheave	1
37.	000-1170-30	#10 Int. Lock washer	1
38.	000-1820-52	Wave Spring Washer	1
39.	000-0347-54	10-24 x 3/8" Round Head PH Machine Screw	2
40.	012-1072-20	Switch trip Bracket	1
40.5	000-1201-02	Micro-Switch	1
41.	012-1002-05	Spindle	1
42.	012-1205-00	Valve Stop Rod	1
43.	025-0150-02	Spanner Wrench	1

### CHUCK BEARING SLIDE ASSEMBLY

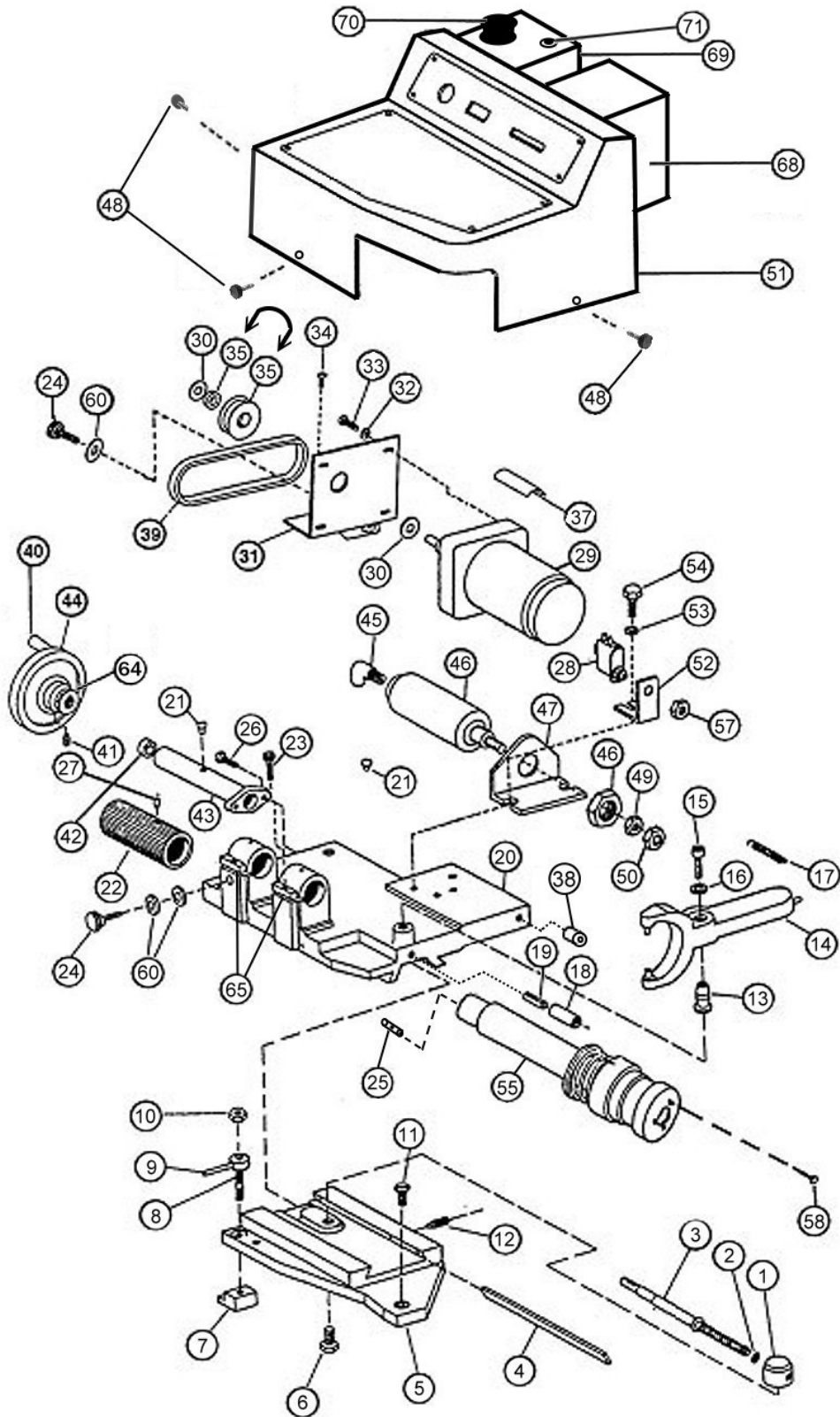

**CHUCK BEARING SLIDE ASSEMBLY**

(SERIAL #12651 AND UP)

Item	Part Number	Description	Quantity
1.	023-0306-08	Feed screw Nut	1
2.	000-2300-57	O Ring	1
3.	012-1046-00	Chuck Bearing Feed screw	1
4.	012-1051-10	Chuck Bearing Slide Gib	1
5.	012-0011-10	Swivel Plate	1
6.	000-0116-57	5/16-18 x 1/2 Hex Head Cap Screw	1
7.	023-0328-05	Swivel Plate Clamp	1
8.	023-0329-02	Stud Clamp Screw	1
9.	023-0330-46	Clamp Screw Collar Assembly.	1
10.	000-1063-21	5/16-24 Hex Jam Nut	1
11.	013-0303-08	Swivel Plate Pivot	1
12.	000-0488-70	5/16-18 x 1 Hex drive cup point set screw w/Nylon strip	3
13.	012-1036-80	Chuck Yoke Pivot	1
14.	012-1035-50	Chuck Yoke Assembly	1
15.	000-0170-51	3/8-16 x 2 socket head cap screw	1
16.	000-1150-37	5/16 Wrought Iron Washer	1
17.	000-1807-26	Chuck Yoke Return Spring	1
18.	003-0050-00	Cap	1
19.	000-7205-65	1/4 x 1-1/2 Roll Pin	1
20.	012-3012-00	Chuck Bearing Slide	1
21.	000-1900-12	1/4 Snap Lid Oiler	5
22.	012-1032-10	Chuck Hand wheel	1
23.	000-0168-02	5/16-18 x 1 socket head cap screw	2
24.	060-1102-50	Thumbscrew Assembly	2
25.	013-0370-19	Chuck Valve Stop, 4mm & H.P. Chuck	1
26.	000-0171-24	1/4-20 x 7/8 socket head cap screw	2
27.	000-0515-36	5/16-24 x 1/4 brass set screw	1
28.	000-1201-02	Micro-Switch	1
29.	012-1045-09	Gear Motor	1
30.	000-1452-03	Collar	1
31.	012-1044-00	Gear Motor Bracket	1
32.	000-1154-60	#10 SAE Washer	4
33.	000-0162-92	10-32 x 3/8 Socket Head Cap Screw	4
34.	000-0592-24	1/4-20 x 1/2 Button Head Cap Screw	2
35.	012-1044-10	Gear Belt Pulley / Clutch Note: Mount flush side away from the motor	1
37.	000-6610-55	Chuck Adjustment Decal	1
38.	012-1080-00	Chuck Cover Spacer	1
39.	001-1899-90	Gear Belt	1
40.	794-8693-53	Hand Knob	1
41.	000-0515-27	1/4-20 x 3/8 Soc. Br. Ft. Pt. S.S.	1
42.	000-9200-96	Oilite Bushing-Feed Screw Housing	1
43.	012-1041-20	Feed screw Bearing. Housing	1
	000-1183-22	3/8" Bow Washer (not shown in diagram)	1
44.	012-1042-10	Feed Hand Wheel Assembly (includes items with 🎵)	1
45.	000-1599-48	Tube Elbow	1

### CHUCK BEARING SLIDE ASSEMBLY

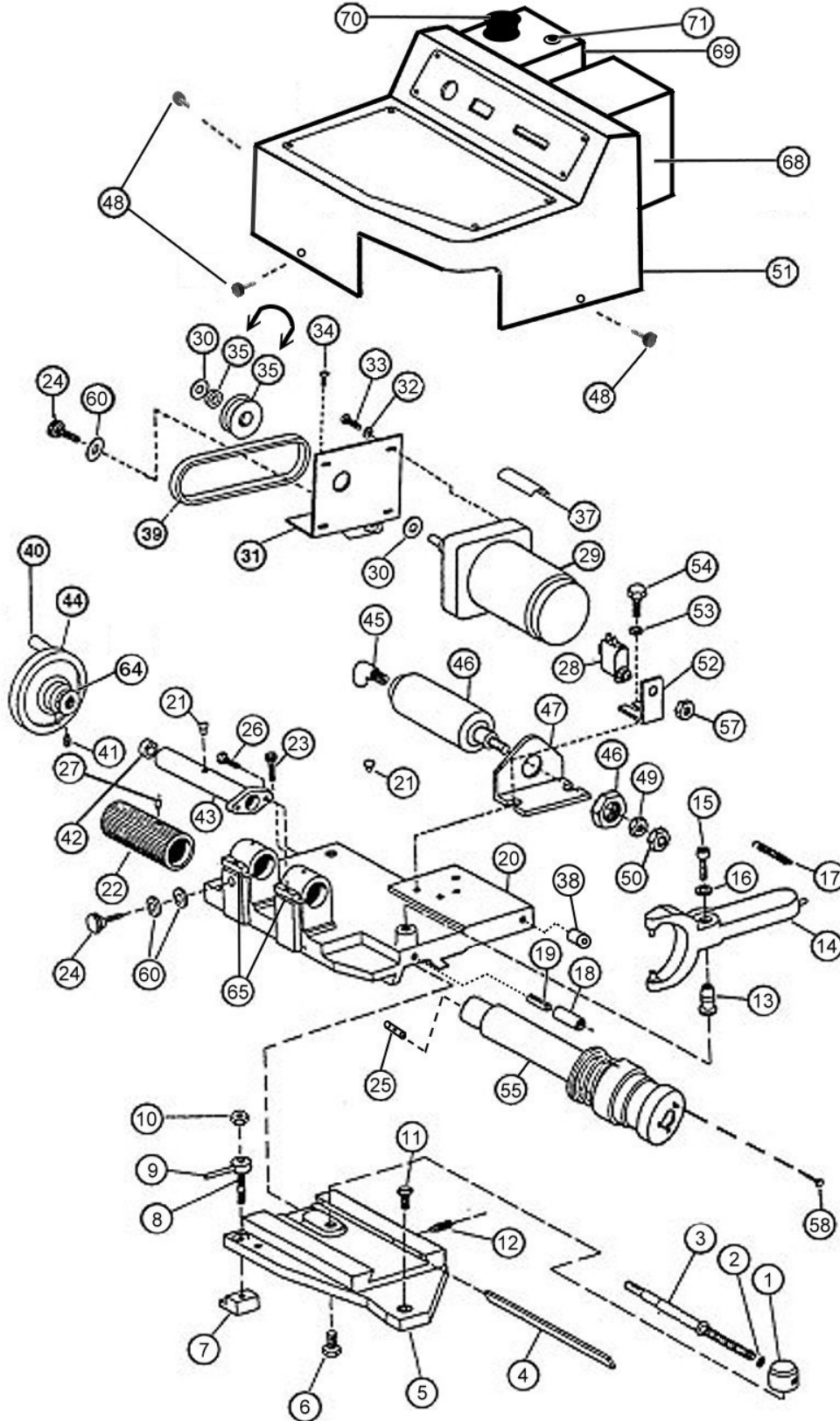

**CHUCK BEARING SLIDE ASSEMBLY  
(SERIAL #12651 AND UP)**

Item	Part Number	Description	Quantity
46.	000-1566-40	Air Cylinder (includes 1-1/4-12 Hex Nut)	1
47.	000-1566-36	Air Cylinder Bracket	1
48.	060-1102-50	Chuck Cover Mounting Screws 1/4-20X3/4	2
48b	060-1130-02	Chuck Cover Mounting Screw 5/16-18	1
49.	000-1070-18	1/2-20 Hex Jam Nut	1
50.	000-1035-51	1/2-20 Hex Full Nut	1
51.*	012-1045-60	Cover/Decals both 50Hz & 60Hz	1
51.*	012-1044-60	Red Cover/Decals both 50Hz & 60Hz	1
52.	012-1044-21	Limit Switch Bracket	1
53.	000-1145-02	1/4 Wrought. Iron Washer	2
54.	000-0167-80	5/16-18 x 3/4 Socket head cap screw	2
55.	012-1575-00	Replacement 4mm Chuck (includes disassembly tool)	1
55.	012-1575-84	Replacement 4mm High Perform. Chuck & disassembly tool	1
25.	013-0370-19	Chuck Valve Stop, 4mm & H.P. Chuck	1
57.	000-1100-32	12mm Hex Nut Zinc Plated	1
58.	000-0590-99	8-32 x 3/8 Socket Head Cap Screw	3
60.	000-1155-25	1/4 SAE Washer	4
64.	000-6611-12	Hand wheel Decal (Std.)	1
64.	000-6611-19	Hand wheel Decal (Metric)	1
65.	000-1740-09	Felt Strip (cut into two pieces)	1
67.	003-0076-50	Speed Controller Knob	1
68.	012-1047-10	Transformer Cover SVSIID 50 Cycle	1
69.	012-1252-50	SVSIID Electrical Box 50 Cycle	1
70	800-8675-49	Emergency Stop Button / Switch	1
71	000-1201-02	Power loss reset button – Micro Switch	1
72	000-1255-10	Circuit Breaker reset Button 10amp (not shown-under cover)	1

\* See part description for part number that applies to your machine

### CHUCK BEARING SLIDE ASSEMBLY

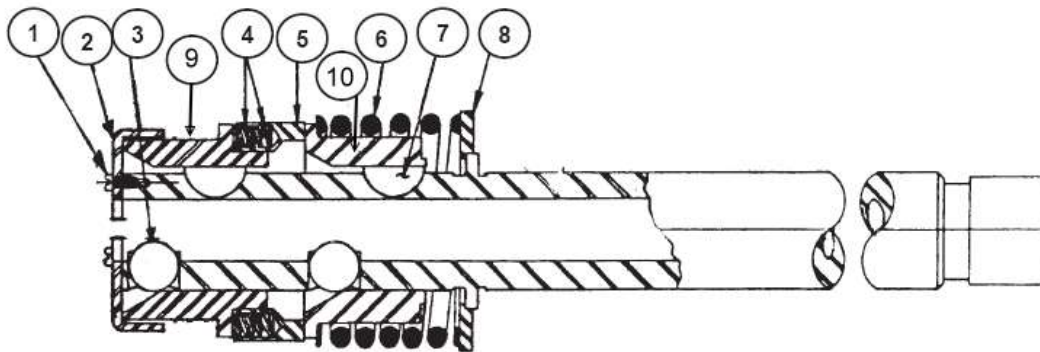

1.	000-0590-99	Special Machine Screw	3
2.	012-1040-24	Chuck Shaft End Cover (replaced 012-1040-22)	1
	000-2300-01	Chuck O-Ring (not shown)	1
3.	010-2101-45	9/16" Steel Ball (set of 6)	1
4.	000-1800-94	Compression Spring for all current models	4
5.		Loading Cup	1
6.	012-1034-17	Chuck Spring	1
7.	012-2000-05	#5 Woodruff Key	2
8.	012-1206-00	Stepped Thrust Spacer	1
		Chuck Shaft – 4 mm	1
9		Outer Chuck Collar	1
10		Inner Chuck Collar	1
	012-1050-12	Protective Chuck Cover	1

**\* The above Chuck Assembly Parts are for replacing lost or damaged during cleaning and are not intended for improving the performance of a worn out chuck. To inquire about replacing your chuck please call +1-319-377-9421.**

NOTE: The valve stop is housed inside the hollow chuck shaft and is not considered as part of the chuck. When replacing your chuck be sure to remove the valve stop from your old chuck and insert it into your new chuck.



Valve Stop  
(PN: 013-0370-19)

## GRINDING OIL PLUMBING ASSEMBLY

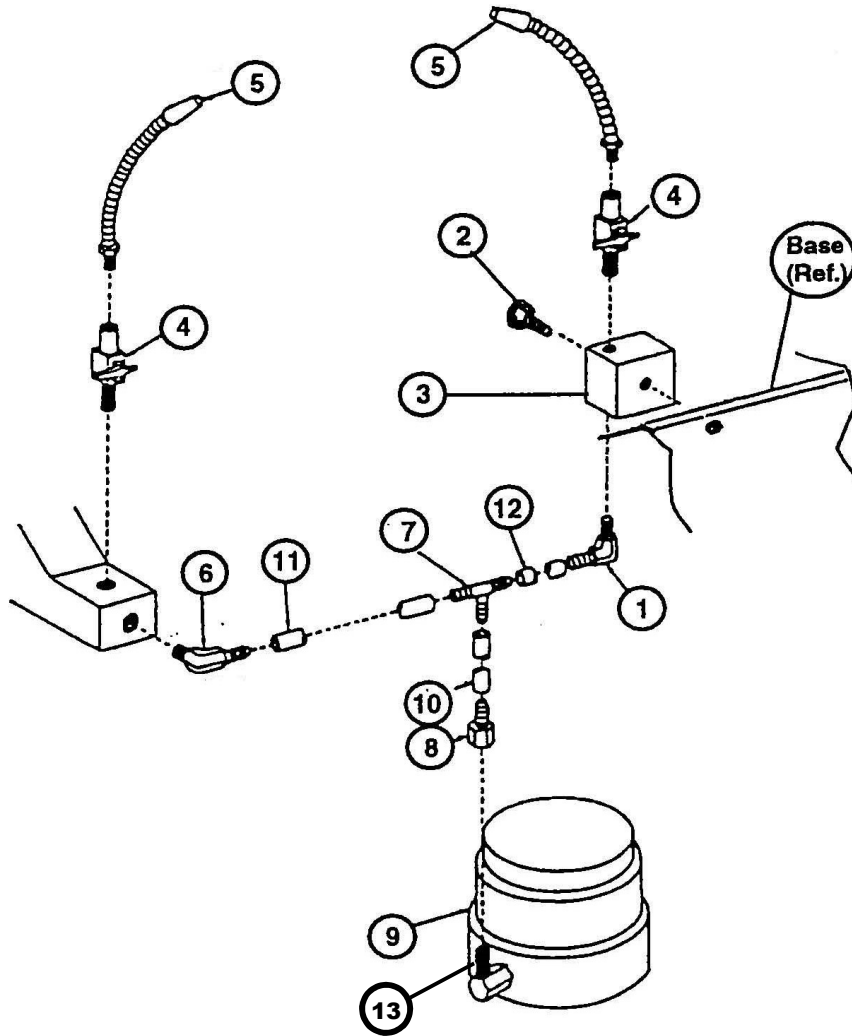

Item	Part Number	Description	Quantity
1.	000-1567-87	90° Elbow 1/4 Barb x 1/4 MPT	1
2.	000-0101-54	1/4-20 x 1-1/2 Hex Head. C.S.	1
3.	012-1045-10	Grinding Oil Nozzle Mount	1
4.	000-1563-68	Plug Valve	2
5.	000-1550-10	Flex Nozzle	2
6.	000-1567-95	90° Elbow, 1/4 Barb x 1/8 MP Brass	1
7.	000-1551-10	Barbed Tee 1/4 ID Hose	1
8.	000-1560-34	1/4 Barb x 1/4 FPT Brass Fitting	1
9.	000-1919-04	Pump 220-50/60-1	1
10.	004-0018-57	1/4 ID x 1/16 Wall PVC Tube (2-1/2" Long)	1 Ft
11.	004-0018-57	1/4 ID x 1/16 Wall PVC Tube (10" Long)	1 Ft
12.	004-0018-57	1/4 ID x 1/16 Wall PVC Tube (15" Long)	1 Ft
13.	000-1556-00	Nylon Elbow 90°	1

# BASE ASSEMBLY

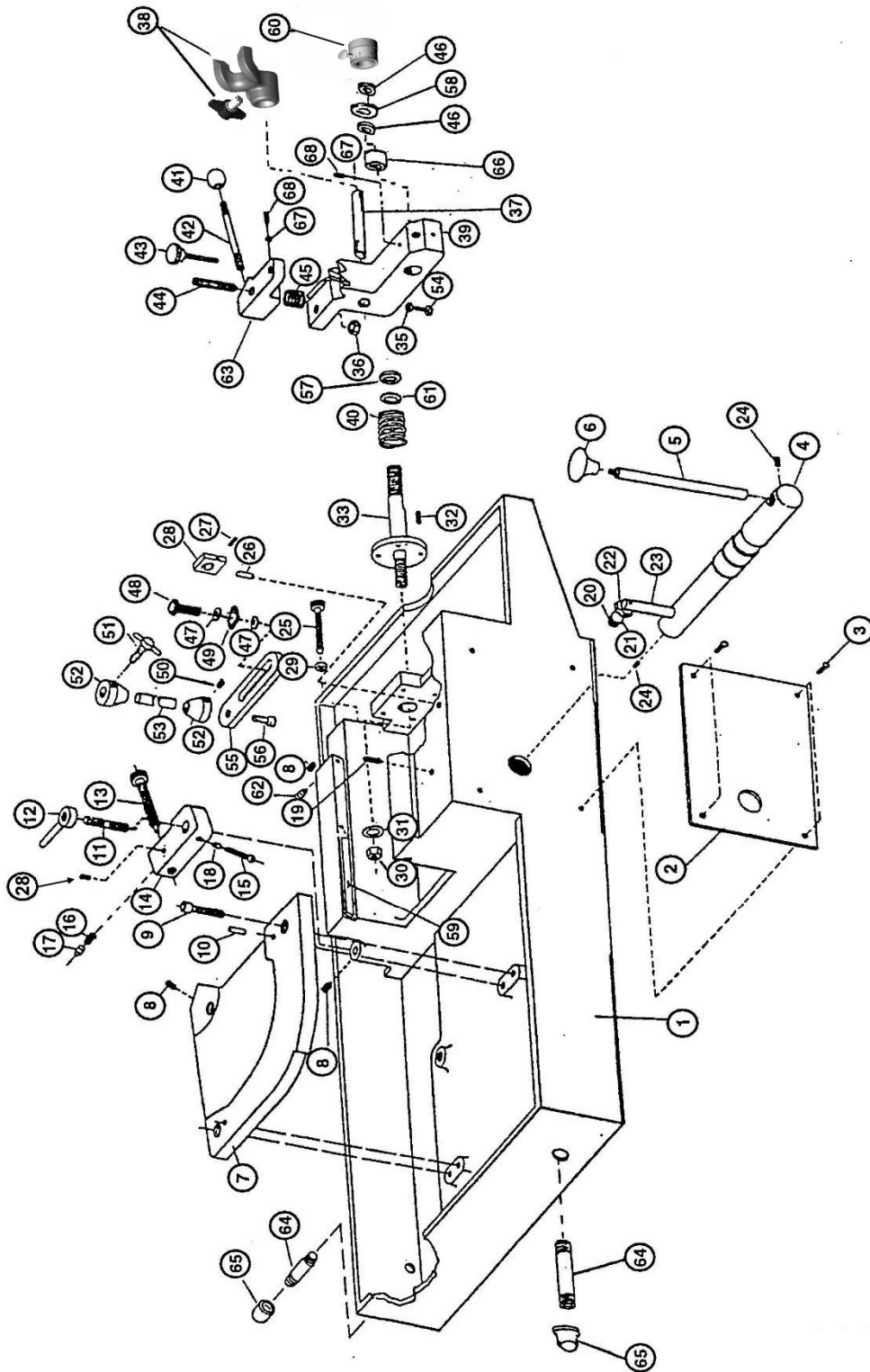

**BASE ASSEMBLY**

<b>Item</b>	<b>Part Number</b>	<b>Description</b>	<b>Quantity</b>
1.	012-3002-10	Base	1
2.	000-6610-23	Base Panel	1
3.	000-0597-06	6 x 5/16 U Drive Screw	4
4.	012-1021-04	Crankshaft Assembly	1
5.	012-1019-10	Traverse Handle	1
6.	004-0015-46	Oval Knob	1
7.	012-0038-03	Base Plate	1
8.	000-0515-00	1/4-20 x 1/4 Socket Brass Flat Pt. Set Screw	3
9.	000-0170-19	3/8-16 x 3/4 Socket head cap screw	3
10.	000-7001-50	1/4 x 7/8 Dowel Pin	2
11.	023-0132-07	Diamond Bracket Lock screw	1
12.	013-0133-14	Lock screw Collar Assembly	1
13.	023-0129-44	Holder-Diamond Nib Assembly	1
14.	012-1006-20	Diamond Holder Bracket	1
15.	000-0213-85	1/4-20 x 1-1/4 Round Head Metal Screw	1
16.	000-1800-76	Compression Spring	1
17.	031-1118-03	Plug	1
18.	000-0500-16	1/4-20 x 1/4 Socket Flat Point Set Screw	1
19.	000-0566-18	1/4-20 x 1 Socket Cone Point. Set Screw	1
20.	000-0166-32	1/4-20 x 1-1/4 Socket Head Cap Screw	1
21.	013-1002-09	5/8 Nylon Pivot	1
22.	000-1020-08	1/4-20 Hex Full Nut	1
23.	013-1003-06	Crankshaft Arm	1
24.	000-0487-63	5/16-18 x 5/16 Socket Cup Set Screw	1
25.	025-0251-05	Stop Screw	1
26.	000-7000-37	1/4 x 1-1/4 Dowel Pin	1
27.	000-0485-10	1/4-20 x 3/16 Socket Cup Point Set Screw	1
28.	000-0482-67	Set screw	1
29.	000-1034-89	5/16-18 Hex Full Nut	1
30.	000-1035-35	1/2-13 Hex Full Nut	1
31.	000-1181-33	1/2 Medium Split Lock washer	1
32.	000-0500-24	1/4-28 x 1/4 Socket Flat Point Set Screw	3
33.	012-1066-22	V-block Pivot Shaft (not included with V-Block Assembly)	1
34.	000-1540-75	1/2-14 Square Head Pipe Plug (Not Shown)	1
35.	000-1040-19	1/4-20 Hex Jam Nut	1
36.	000-1045-15	3/8-16 Hex Jam Nut	1
37.	025-0636-00	Valve Stop Rod (see more details on page 44)	1
38.	025-0635-03	Valve Stem Stop (see more details on page 44)	1
39.	012-1009-16	V-block Assembly (see more details on page 44)	1
40.	000-1808-23	Compression Spring	1
41.	000-4500-22	Knob-Ball	1
42.	012-1055-09	Clamp Lever Handle	1
43.	012-1039-30	Clamp Screw Assembly	1
44.	000-0491-23	3/8-16 x 2 Soc. Hd. Cup Pt SS	1
45.	000-1807-00	Compression Spring	1

**\*\* Continues on next page \*\***

### BASE ASSEMBLY (CONTINUED)

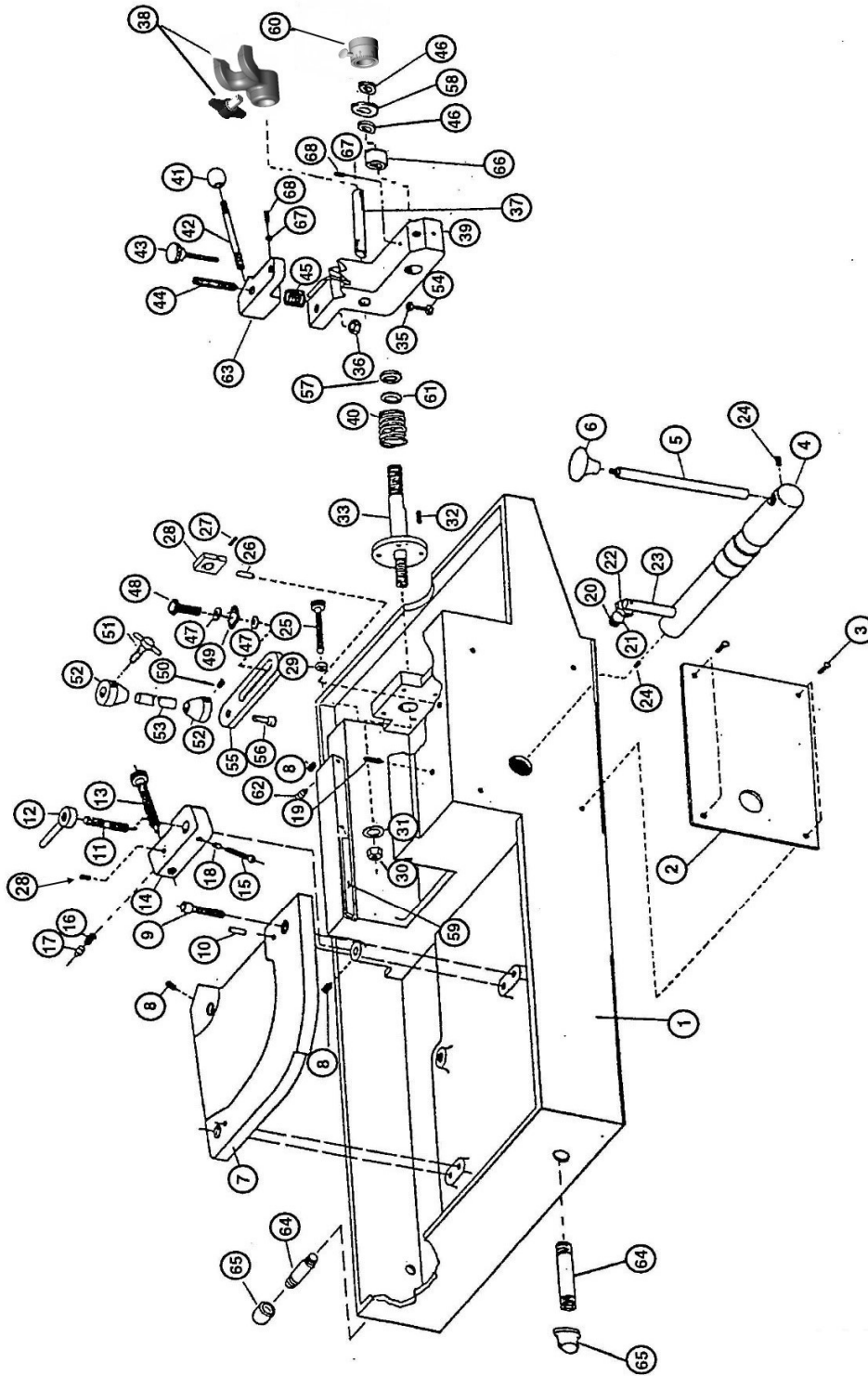

**BASE ASSEMBLY (CONTINUED)**

Item	Part Number	Description	Quantity
46.	000-1624-10	Thrust Washer	2
47.	000-1150-37	5/16 Wrought Iron Washer	2
48.	000-0105-53	3/16-18 x 1-1/4 Hex Head. C.S	1
49.	000-1183-22	3/8 Spring Washer	1
51.	060-1130-02	T-Bar thumbscrew Assembly ♦♦	1
52.	015-0837-43	Rocker Arm Cone ♦♦	2
53.	023-0836-04	Rocker Arm Attachment Post ♦♦	1
54.	000-0100-65	1/4-20 x 1-1/4 Hex Hd. C.S.	1
55.	023-0835-07	Rocker Arm Attachment Base ♦♦	1
56.	000-0167-64	5/16-18 x 1/2 Soc. Head Cap Screw ♦♦	1
57.	000-1158-00	1-1/8 x 3/4 x 3/16 Felt Washer	1
58.	000-1624-00	Thrust Needle Bearing	1
59.	012-1051-50	New Style Gib	1
60.	012-1064-08	Feed nut Assembly Standard	1
61.	000-1142-12	3/4 Machine Bushing	1
62.	000-0488-70	5/16-18 x 1 cup point socket set screw w/ Nylon	6
63.	012-1007-01	Clamp Lever	1
64.	000-1502-74	1/2 x 3-1/2 Pipe Nipple TBE	2
65.	000-1540-83	1/2 Black Pipe Cup	2
66.	012-1066-80	Cup, Marker	1
67.	000-6400-26	Lock screw Plug	2
68.	000-0486-40	1/4-20 x 1/4 Socket cup point set screw w/Nylon	1
69.	000-0485-10	1/4-20 x 3/16 Socket cup point set screw (not shown)	1
70.	012-1208-00	Grinding Oil Splash Guard (not shown)	1



**012-1120-00 Rocker Arm Attachment Assembly**  
 (Items marked with "♦♦" above are included in this assembly)

**PN: 012-0160-00**  
**V-BLOCK ASSEMBLY**

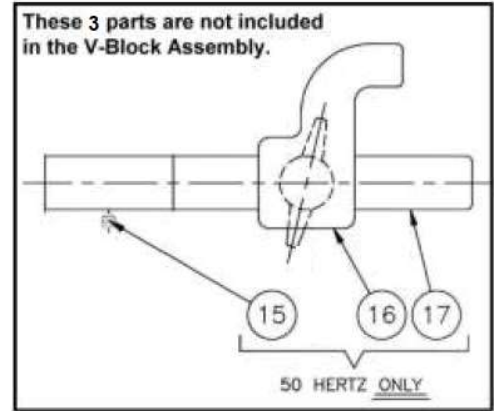
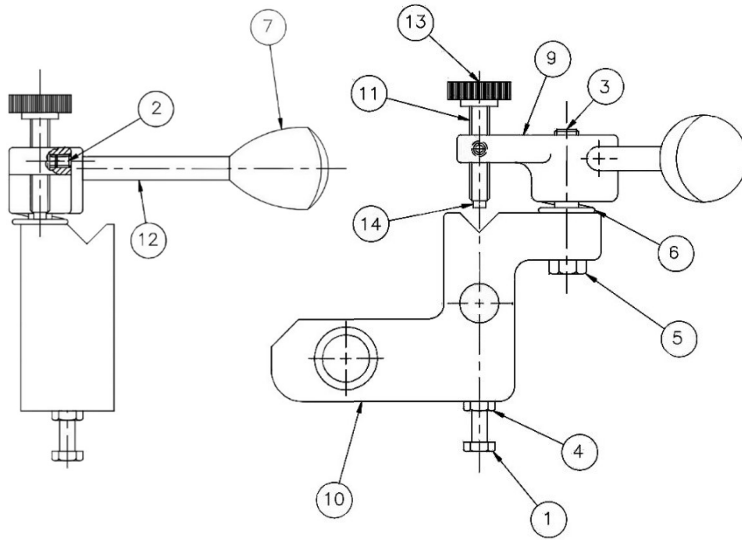

Item	Part Number	Description	Quantity
1.	000-0100-65	¼ - 20 X 1-1/4 Hex HD Cap Screw	1
2.	000-0486-40	Nylon Socket Cup Set Screw	1
3.	000-0491-23	3/8 – 16 x 2 Socket Cup Pt. S.S.	1
4.	000-1040-19	¼ - 20 Hex Jam Nut	1
5.	000-1045-15	3/8 – 16 Hex Jam Nut	1
6.	000-1807-00	Compression Spring	1
7.	000-4500-22	5/16 – 18 Tapered Oval Handle	1
9.	012-1007-01	Clamp Lever	1
10.	012-1009-16	V-Block Assembly	1
11.	012-1039-05	Screw Clamp 5/16 – 18 x 1.50	1
12.	012-1055-09	Lever Handle Clamp	1
13.	000-0760-82	Thumbscrew Cap 5/16	1
14.	081-0911-02	Cam Setscrew plug	1
15.	000-0500-16	1/4" Flat Point Setscrew	1
16.	025-0635-03	Valve Stop Assembly (includes thumb screw)	1
17.	025-0636-00	Valve Stop Rod	1

The Valve Stop with 3 additional parts listed above is used to guide the valve stem length when grinding the top of the valve stem. This helps to insure that valve stems are all the exact same length. While this is not necessary for most engines, it can help with some engine models that are not easily adjusted or that have much tighter tolerances. The Valve Stop parts are added to the V-Block Assembly and are purchased separately as their individual part number listed above.

### AIR PLUMBING ASSEMBLY

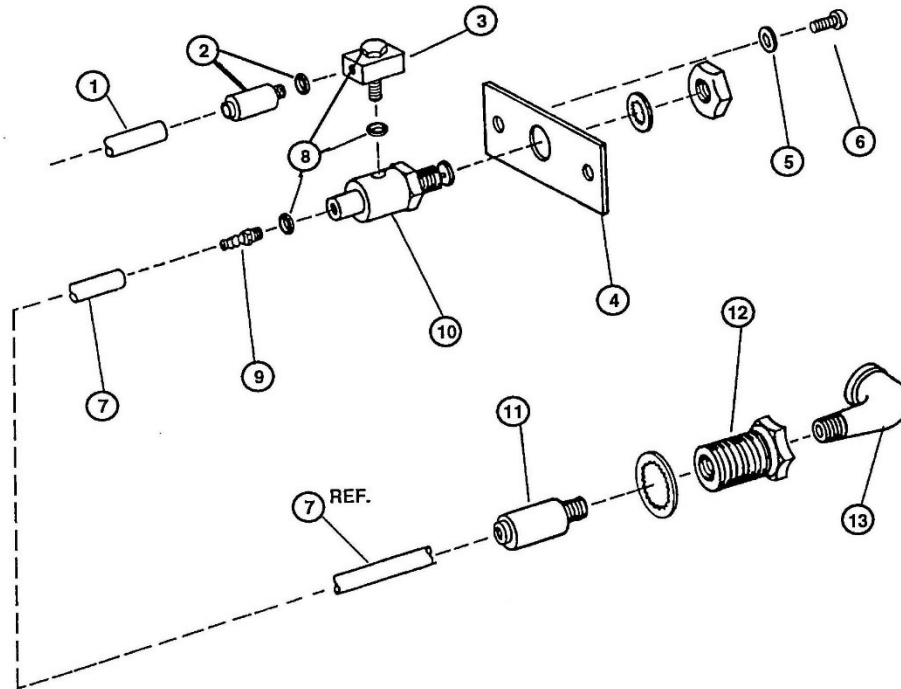

Item	Part Number	Description	Quantity
1.		5/32 O.D. Tubing	4 Ft
2.		10-32 Max 5/32 Str. Fitting	1
3.		10-32 Univ. El Fitting	1
4.		Air Switch Mounting Plate	1
5.	000-1170-48	1/4 Int. Lock washer	2
6.	000-0213-77	1/4-20 x 3/8 Rd. Head MS	2
7.		1/4 O.D. Tubing	1 Ft
8.		Gasket (now included with parts)	3
9.		10-32 Max 1/4 Str. Fitting	1
10.		3 Way Air Valve	1
11.	000-1599-25	1/4 x 1/4 Tube-In Str. Fitting	1
12.	000-1559-34	Bulkhead Fitting	1
13.	000-1530-28	1/4 x 90° Street Elbow	1

#### AIR VALVE SWITCH ASSEMBLY

(PN: 012-1094-00)

Pictured on the right and includes all parts not shown in table above.

Assembled and tested against air leakage for quick and easy installation.

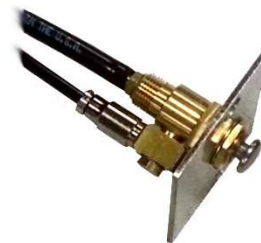

### 220V/50HZ/1PH WIRING DIAGRAM

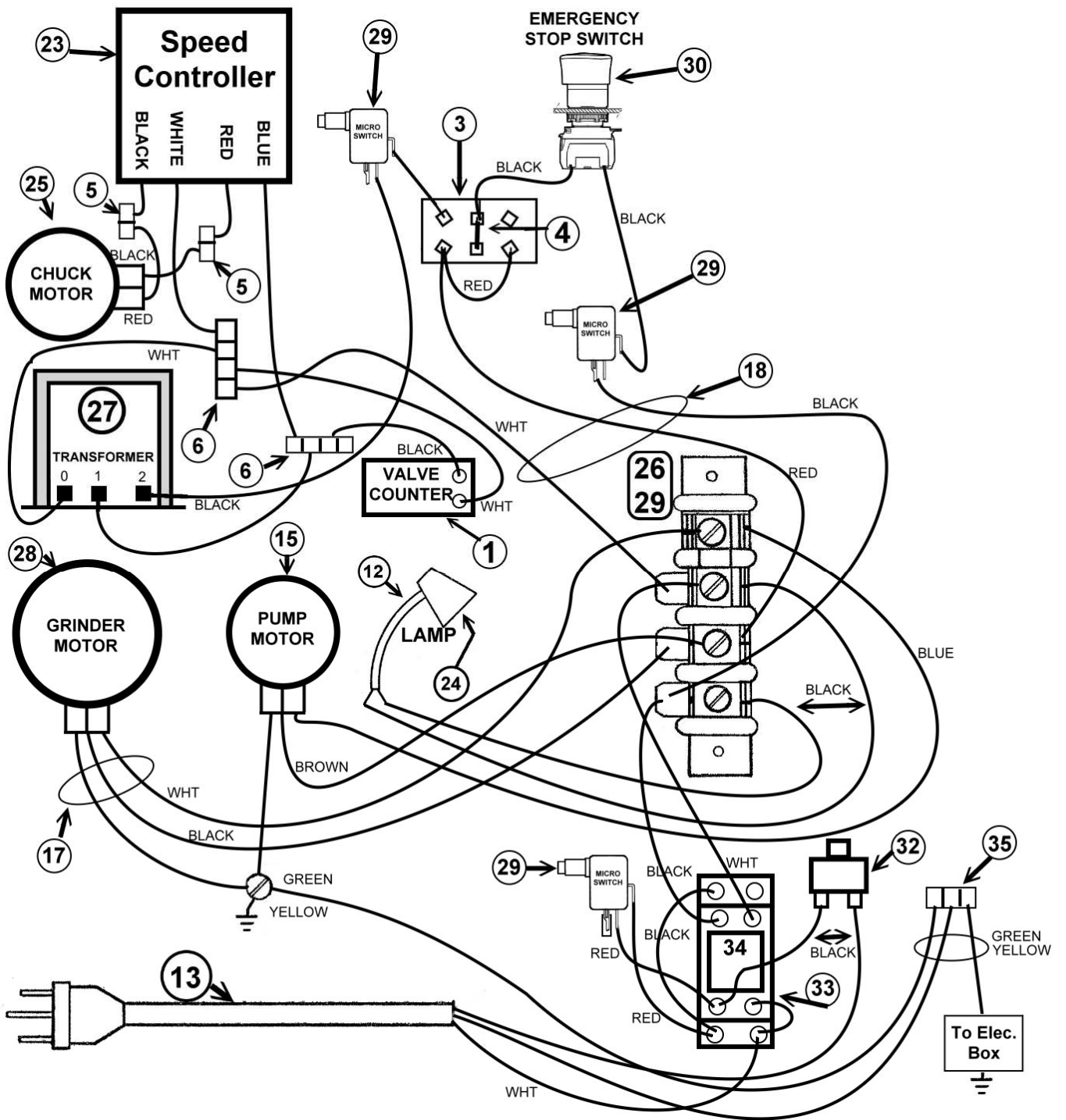

**220V/50HZ/1PH WIRING DIAGRAM (SERIAL # 12651 AND UP)**

Item	Part Number	Description	Quantity
1.	000-1191-50	Counter, Valve	1
2.	000-1201-02	Micro-Switch	2
3.	000-1205-26	Rocker Switch	1
4.	000-1241-00	Term, QD (12-10) 1/4 Full Ins.	2
5.	000-1244-01	1 Conductor Lever Nut Inline Butt Connector	2
6.	000-1244-05	5-Conductor Splicing Lever Nut Connector	2
7.	000-1242-49	Term, Female Flag 1/4	2
8.	000-1242-49	Term, Female Flag 1/4	2
9.	000-1100-32	12mm Hex Nut Zinc Plated	4
10.		Term, Hook (16-14) #10	2
11.		Term, Hook (12-10) #10	1
12.	000-1252-18	Lamp (no bulb)	1
13.	000-2403-38	Set, Cord - 16-3SJO	1
15.	000-1919-04	Pump 220V-50/60Hz-1Ph (pump only)	1
16.	000-2401-92	Wire, Blue 16GA 20" Lg.	2 Ft
17.	000-2403-38	Cord, 16-3SJO 28" Lg.	3 Ft
18.	000-2403-70	Cord, 16-4SJO 55" Lg.	5 Ft
19.	000-2410-24	Wire, Black 16GA 4" Lg.	2 Ft.
20.	000-2410-59	Wire, Red 16GA 4" Lg.	1 Ft
22.	800-8063-33	Wire, Brown 16GA 20" Lg.	2 Ft
23.	000-6700-70	Controller, Speed 115V	1
24.	001-1601-76	115v-230v LED Lightbulb	1
25.	012-1045-09	Gear Motor, PM 1/12 HP	1
26.	004-0034-72	Block, Term-4P-1/4 Tabs	1
27.	000-1274-90	Transformer – 150VA	1
28.	001-1949-95	Motor-1/2 115/230-50/60-1	1
29.	000-1242-70	Term, Q Disc (16-14) Fully Ins. 1/4	19
	012-1047-10	Transformer Cover (not shown)	1
	000-0391-10	Transformer Cover Screw (not shown)	2
	013-1008-75	Pump Assembly for 220v 50Hz machines	1
30.	800-8675-49	Emergency Stop Button	1
31.	000-1201-02	Micro-Switch	1
32.	000-1255-10	Circuit Breaker Button / 10 amp	1
33.	000-1255-15	Relay Socket – 8 pin	1
34.	000-1255-20	Power Relay 240v A/C	1
35.	000-1244-03	3 - wire Wago connector	1
	(013-1008-75 includes the following)		
	000-1244-19	Eye Terminal (16-14) #10	1
	000-1242-70	(16-14) – 1/4F Vinyl Insulated Terminal	2
	000-1556-00	90 Deg. Plastic Elbow	1
	000-1560-34	1/4" Barb x 1/4" FPT Brass SL	1
	000-1919-04	205 GPH @1.0 FT-230v Pump	1
	004-0018-57	1/4ID x 1/16WA.PVC Tube	1.25

**PN: 012-1006-71**  
**WHEEL DRESSER BRACKET ASSEMBLY**

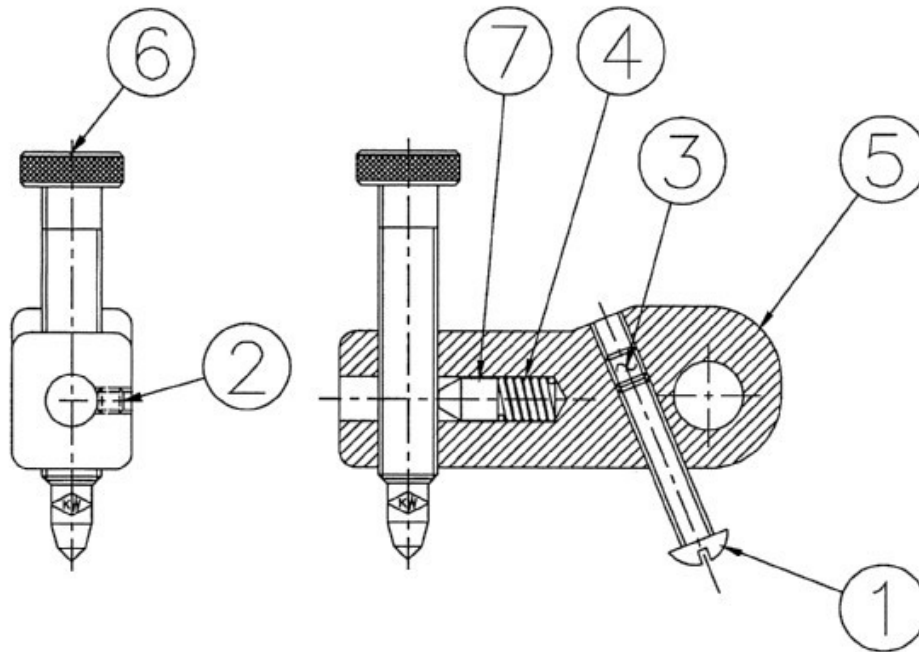

Item	Part Number	Description	Quantity
1.	000-0213-85	¼ - 2- x 1 – ¼ Round Head Machine Screw	1
2.	000-0482-67	10 – 24x3/16 Socket cup Point Set Screw	1
3.	000-0500-16	¼ - 20 x ¼ Socket Flat Point Set Screw	1
4.	000-1800-76	Compression Spring	1
5.	012-1006-20	Diamond Holder Bracket	1
6.	023-0129-44	Valve Diamond	1
7.	031-1118-03	Brass Plug	1

Note: Setscrew (Item 2) is used to retain the Plug (Item 7) until the Diamond (Item 6) is in position. After this bracket assembly is installed, the setscrew must be backed off to allow the plug to contact the Diamond threads.

### **REPLACING THE DIAMOND DRESSER**

Before removing the old dresser diamond you must tighten down the set screw (#2) on the diamond dresser holder. This holds the brass pointed tensioner (#7) in place back away from the diamond threads while changing out the diamond. Failure to do this step will make it impossible to screw in the new diamond holder. And could damage the new diamond or the brass pointed tensioner. If neither has been damaged but the set screw was not tightened before removal, one person will have to push the brass tensioner in while another person tightens the set screw to hold in in place. Then the new diamond can be threaded in. This is usually discovered when having difficulty inserting a new diamond. The user discovers the tensioner has come out too far and the new diamond won't go in.

## VALVE REFACING SUPPLIES

### KWIK-WAY SIX BALL CHUCKS

#### The Key to the KWIK-WAY “Centerline” Chuck System

Every **KWIK-WAY** chuck features two sets of 3 hardened steel balls - one set in the front of the chuck and the other set in the rear of the chuck - that grasp the valve on the portion of the stem that travels within the valve guide. It automatically aligns the valve stem, allowing the valve face to be refaced concentric to the valve stem.

This precision six-ball self-centering chuck requires no stem chamfering or butt grinding prior to refacing.

The **KWIK-WAY** Centerline System assures alignment and accuracy, providing precision valve refacing.

### VALVE REFACER CHUCKS

MODEL	VALVE STEM DIAMETER CAPACITY	ITEM NUMBER
SVS II-D	0.157" – 0.5625" 4.0 mm – 14.3 mm	012-1575-00 (w/disassembly tool)
SVS II-D	7/16" – 13/16" 11.11 mm – 20.6 mm	012-1025-21*

\* Requires 012-1035-21 Chuck Yoke

Existing machines in the field may require the chuck cover to be modified to fit new chuck and chuck yoke.

### 7" (177MM) VALVE REFACING WHEELS

010-0710-08	Finishing 7"
010-0709-00	General Purpose 7"
010-0708-05	Titanium 7"
010-0707-50	Stellite 7"

### 3" (76 MM) STEM WHEELS

010-0300-72	For General Purpose Stem Grinding
010-0300-13	For Rocker Arm Grinding

### VALVE GRINDING OILS

Proper Lubrication is necessary for quality valve finishes, abrasive performance and machine life

ITEM	DESCRIPTION
000-2112-73	1 Gallon (3.6L) Valve Grinding Oil
000-2111-92	5 Gallon (18L) Valve Grinding Oil
000-2111-66	Keyser's Mirror Finish Valve Grinding Aid

## VALVE REFACER DIAMOND TOOLS

Replacement tools for dressing either valve or butt wheels on valve refacers. Quality oversized diamond tips last longer. Produce different wheel surfaces by varying the amount and speed of stock removal.

**SHOP TIP!**

A.

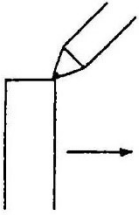

A. Feed diamond up to contact, then traverse from left to right. This will open the abrasive, causing a faster stock removal on valve.

B.

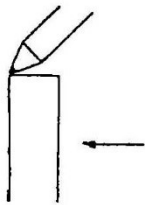

B. Feed diamond up to contact, then traverse from right to left. This will close the abrasive, causing a smoother finish but a slower stock removal and a faster load up of wheel.

C.

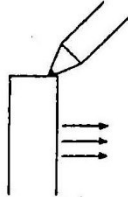

C. A faster traverse into the diamond point will cause the wheel to act softer. Recommended for hard alloy valves.

D.

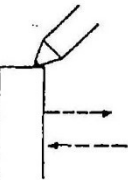

D. A slower traverse into the diamond point and then a sweep back with **NO** additional feed up will cause the wheel to act hard. This is recommended for polished surface finishes.

MODEL	DESCRIPTION	ITEM
SVS II-D Size: 7/16" Threads: 20 x 1-7/8"	Valve Wheel Diamond	023-0129-44
SVS II-D Size: 5/16" No Thread	Butt Wheel Diamond	024-0131-11



*Valve Wheel Diamond*

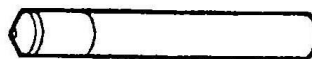

*Butt Wheel Diamond*

## OPTIONAL ACCESSORIES

DESCRIPTION	ASSEMBLY	ITEM
Valve Refacer Cabinet	37w x 22d x 36h	012-0039-00
Cabinet Shelf	Internal Shelf (replacement)	012-0301-00
Cabinet Shelf Clips	4 Total Needed	006-5000-13
H.P. Small Valve Collet Chuck	3.0 mm – 6.0 mm	012-1575-60
Optional Foot Pedal Switch	Air operated Foot Switch for Chuck activation.	012-0400-00

### Valve Refacer Cabinet

Heavy-duty unit with spacious cabinet and valve storage rack mounted on side. Holds all your valve grinding supplies (37" wide x 22" deep x 36" high) cabinet for all **KWIK-WAY** bench top valve refacers.

### Foot Pedal Air Switch

Hands-Free Chuck Operation!

- Increase Production
- Shorten Cycle Times

### High Performance Small Valve Collet Kit

Permits grinding smaller valves without changing chucks. Collet fits into chuck and holds valves with small stem diameters or length. High Performance because this isn't your typical small collet chuck. We did our research and provide a small collet chuck that meets the Kwik-Way standards for accuracy. Includes the following collets:

PART NUMBER	COLLET SIZE (MM)	DECIMAL
012-1575-61	HP Collet Extension	N/A
012-1575-62	3.00 mm	0.118
012-1575-63	4.00 mm	0.157
012-1575-65	5.00 mm	0.196
012-1575-66	6.00 mm	0.236
<b>OPTIONAL</b>		
012-1575-53	3.50 mm	0.138
012-1575-54	4.50 mm	0.177
012-1575-55	5.50 mm	0.217
012-1575-56	6.50 mm	0.256



012-0039-00  
Valve Refacer Cabinet



012-1575-60  
High Performance  
Small Collet Chuck Kit



012-0400-00  
Foot Pedal Activated  
Chuck Switch

## TROUBLE SHOOTING GUIDE

CONDITIONS	POSSIBLE CAUSE
1. Spindle Motor and/or chuck motor will not operate	<ol style="list-style-type: none"> <li>1. Power Loss Reset Button (Check possible relay failure if no power)</li> <li>2. Circuit Breaker Reset Button</li> <li>3. Line fuse is open. Check fuse/breaker.</li> <li>4. Power cord un-plugged</li> <li>5. Loose or broken wire(s).</li> </ol>
2. Spindle lacks power.	<ol style="list-style-type: none"> <li>1. Loose "O" Ring belts. Replace.</li> <li>2. Line voltage incorrect for motor, check motor input tag current supply.</li> </ol>
3. Spindle motor will not start when the main switch is turned on	<ol style="list-style-type: none"> <li>1. Spindle slide in far right location. NOTE: This machine is equipped with an automatic limit switch when the spindle slide is on the far right location.</li> <li>2. Limit switch is out of adjustment.</li> <li>3. Power Loss Reset Button needs to be pressed</li> <li>4. Circuit Breaker Button needs to be pressed to reset</li> </ol>
4. Wheel face rough after facing.	<ol style="list-style-type: none"> <li>1. Feeding the wheel across the diamond too rapidly.</li> <li>2. Broken diamond. Replace.</li> <li>3. Diamond tool holder not locked tight.</li> <li>4. Blunt diamond. Replace.</li> </ol>
5. Poor finish on valves (Chatter)	<ol style="list-style-type: none"> <li>1. Check wheel dress.</li> <li>2. Chuck out of adjustment.</li> <li>3. Slide out of adjustment.</li> <li>4. Spindle bearings worn.</li> <li>5. Chuck Motor Belt too tight. (should be as loose as possible without it slipping)</li> </ol> <p><b>NOTE:</b> See page 18 on varying wheel performance.</p>
6. Grinding sounds heavier on one side of the valve face over the other.	<ol style="list-style-type: none"> <li>1. Check the Gib adjustments on both the Chuck and spindle side. Especially on the chuck side it's possible for one of the spring loaded gib adjustment screws to be stuck causing a miss-alignment of the chuck shaft.</li> </ol>
7. Chuck open and close action seems sticky.	<ol style="list-style-type: none"> <li>1. This is almost always due to debris in the chuck and a full disassembly and cleaning with denatured alcohol will solve it.</li> </ol> <p><b>NOTE: If your machine is new we encourage you to spray ATF onto and into the chuck opening along where the valve stem is inserted while opening and closing the chuck using the air switch. This will ensure the chuck operates correctly.</b></p>

## *END-OF-LIFE DISPOSAL*

This equipment should be disposed of in accordance with EU regulations, specifically the **Waste Electrical and Electronic Equipment (WEEE)** Directive and any relevant national laws or the regulations that govern the area where disposal will take place.

### **WEEE Directive Compliance**

- **Take-Back Systems:** Check with your local retailer or waste management authority for information on take-back systems in your area. These systems often provide free collection and recycling of WEEE.
- **Authorized Collection Points:** You can also dispose of the equipment at authorized collection points designated by your local authorities.

### **Hazardous Substances**

- **RoHS Compliance:** This product complies with the Restriction of Hazardous Substances (RoHS) Directive, which limits the use of certain harmful substances in electronic equipment.

### **For more information:**

- **Local Authorities:** Contact your local waste management authority for specific guidelines and collection points.

**Please note:** It's essential to comply with the WEEE Directive and any relevant national laws to ensure proper disposal and minimize environmental impact.

## *Stay Updated with kwik-way.com*

For the latest information and support on your machine, visit [kwik-way.com](http://kwik-way.com).

- **Free Manual Downloads:** Find the most recent version of this manual.
- **Replacement Parts:** View photos, descriptions, and pricing for common replacement parts.
  - **International Customers:** Contact International Sales at +1 319-377-9421 or [international@kwik-way.com](mailto:international@kwik-way.com).
- **Helpful Resources:**
  - Videos showing helpful information
  - Blog articles for tips, troubleshooting, and best practices.
  - Sale Announcements

And of course you are welcome to give us a call with your questions or concerns. We have long time distributors in several countries all over the world who are will and ready to help.

International Sales at +1 310-377-9421 or email: [international@kwik-way.com](mailto:international@kwik-way.com)





**Ironite Products Inc.**  
Manufacturer of Kwik-Way, Van Norman, and  
Ironite Brands  
2525 18<sup>th</sup> St. SW, Cedar Rapids, IA 52404 USA  
+1-319-377-9421  
+1-319-377-9101 (FAX)

[www.ironite.com](http://www.ironite.com) - [www.kwik-way.com](http://www.kwik-way.com) - [www.van-norman.com](http://www.van-norman.com)